



TA-Smart

DN 15-50



TA-Smart

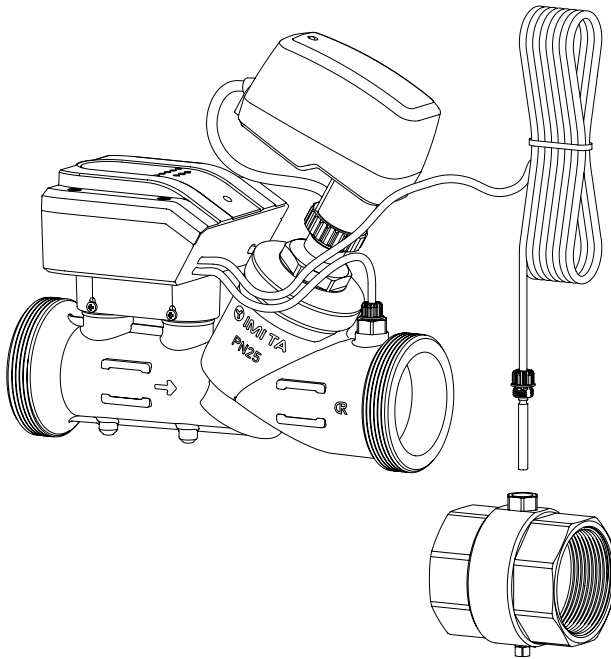



- Intendend use: For measuring and control in heating and cooling systems.
- The water quality requirements described in VDI2035 should be respected.
- TA-Smart can be cleansed with a dampd cloth and a lenient cleaning agent.
- Insulated wires and cables shall retard flame propagation with a flammability RATING of UL 2556 VW-1 or equivalent.

- 用途:用于供热和制冷系统的测量和控制.
- 应遵守VDI2035中描述的水质要求.
- TA-Smart可以用湿布和温和的清洁剂清洁。
- 绝缘电线和电缆的可燃性等级应达到UL 2556 VW-1或同等等级，以减缓火焰传播。



24 VAC/VDC operating only with safety isolating transformer according EN 61558-2-6.

仅依照 EN 61558-2-6 带有安全变压器时才能实现 24 VAC/VDC 运行。

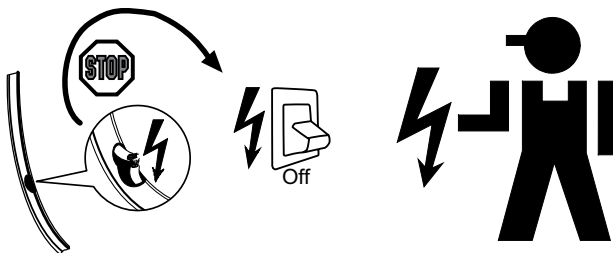

Service/Repair
服务/维修

→ ☎ IMI Hydronic Engineering



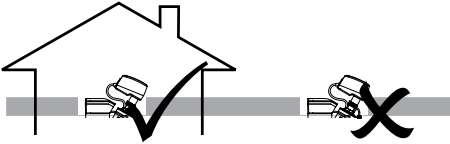
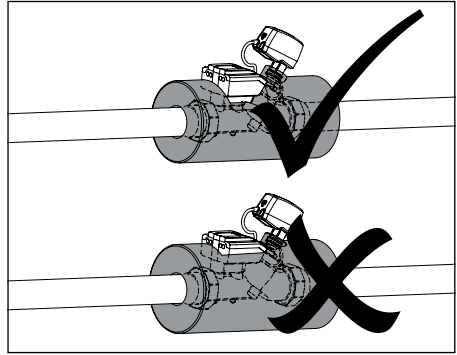
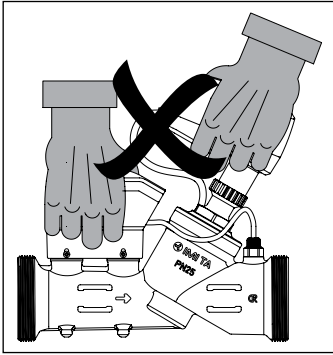

If the TA-Smart is used in any other application than specified by IMI Hydronic Engineering the protection provided by the equipment may be impaired.

如果TA-Smart用于IMI Hydronic Engineering规定以外的任何其他应用，则设备提供的保护可能会受损。

We reserve the right to introduce technical alterations without prior notice.
我们保留引进技术变更的权利，恕不另行通知。

Technical specifications valid at an altitude of max. 2000 m.
技术规范有效的最高海拔高度为2000米。



-20° C - +70° C (-4° F - +158° F)
(5-95%RH, non-condensing/相对湿度 5-95%, 无冷凝)



0° C - +50° C (32° F - +122° F)
(5-95%RH, non-condensing/相对湿度 5-95%, 无冷凝)



Input signal/输入信号: 0-10 VDC
Output signal/输出信号: 0-10 VDC
Control mode/控制方式: Flow/流量

Flow setting/流量设定: q_{nom}
Media/介质: H₂O
Characteristic/特性: EQM

(A)

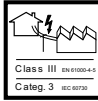

Software
A
EN 60730

Type
1AB
EN 60730

IP54
EN 60730



(B)

BACnet MS/TP, BACnet IP, Modbus RTU, Modbus TCP
Proportional/比例:
0(2)-10 VDC 47 k Ω 0(4)-20 mA, 500 Ω

Power supply/工作电压:

24 VAC +6%/-10%, 50/60 Hz \pm 15% 24 VDC +15%/-10%

Power consumption/功率:

- Operating/运行: < 5.6 VA (VAC); < 4.0 W (VDC)
- Standby/待机: < 3.3 VA (VAC); < 1.9 W (VDC)

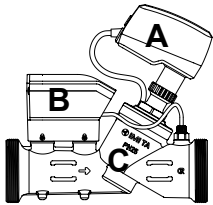

EN 61010



Contains Transmitter Module FCC ID:
X8WBC840M



(C)

-10° C - +110° C (14° F - +230° F)
Water and water-glycol mixtures (0-57%)/
水或和乙二醇水溶液 (0-57%)

PN 25 (362 psi)

DpV min. 5 kPa (0.7 psi) max. 400 kPa (58 psi)

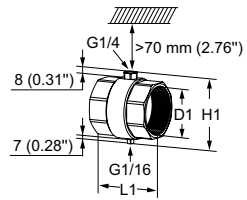
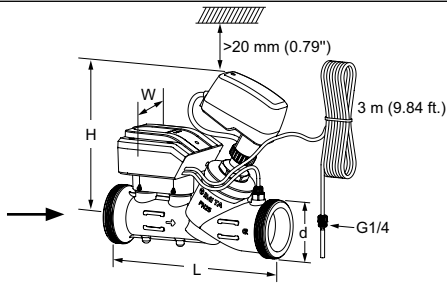

ISO				
DN	d	L [mm]	H [mm]	W [mm]
15	G3/4	167	173	97
20	G1	180	174	97
25	G1 1/4	187	174	97
32	G1 1/2	200	199	97
40	G2	218	198	97
50	G2 1/2	239	198	97

Size	d	L [in]	H [in]	W [in]
1/2"	G3/4	6.57	6.81	3.82
3/4"	G1	7.09	6.85	3.82
1"	G1 1/4	7.36	6.85	3.82
1 1/4"	G1 1/2	7.87	7.83	3.82
1 1/2"	G2	8.58	7.79	3.82
2"	G2 1/2	9.41	7.79	3.82

ISO			NPT		
D1	L1 [mm]	H1 [mm]	D1	L1 [mm]	H1 [mm]
G1/2	48	55	1/2"	52	55
G3/4	60	56	3/4"	55	56
G1	62	61	1"	64	61
G1 1/4	70	71	1 1/4"	66	71
G1 1/2	70	77	1 1/2"	67	77
G2	78	89	2"	68	89

	D1	L1 [in]	H1 [in]
	1/2"	2.05	2.17
	3/4"	2.17	2.20
	1"	2.52	2.40
	1 1/4"	2.60	2.79
	1 1/2"	2.64	3.03
	2"	2.68	3.50

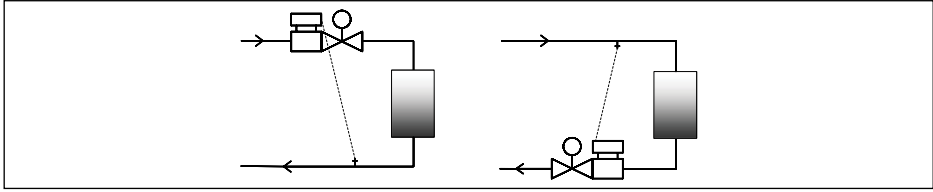
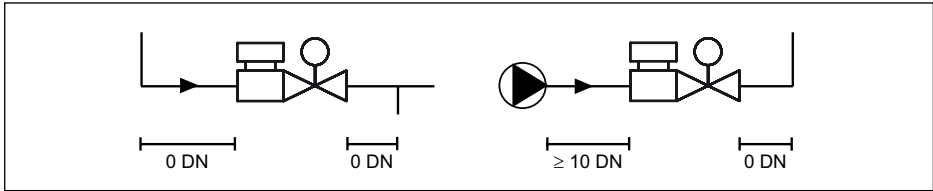
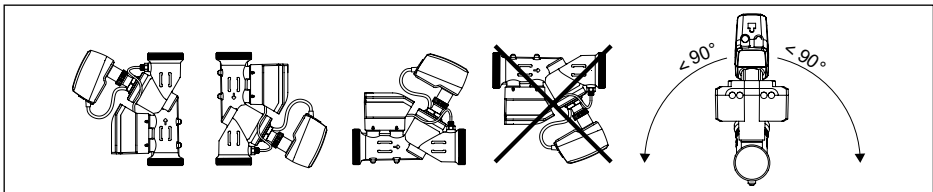

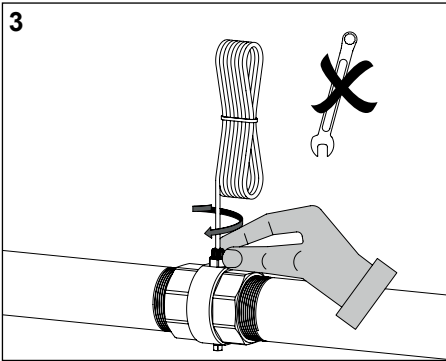
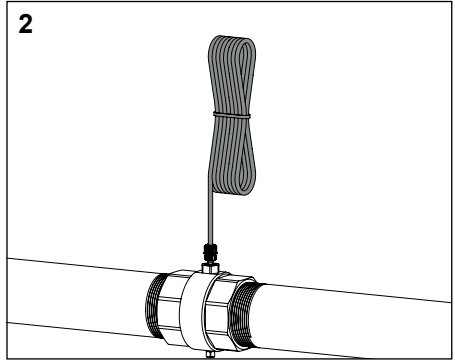
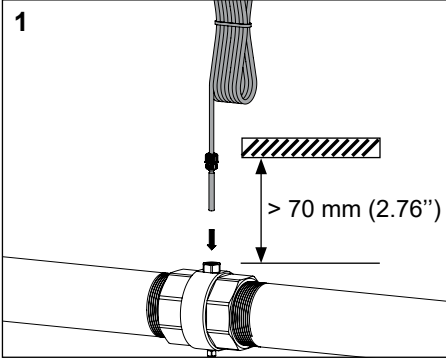



**Optional!
可选!**

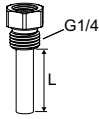

Art. No./产品编号

DN 15-25 (3/4" - 1") : 322230-00401, L = 14 mm (0.55 in.)

DN 32-50 (1 1/4" - 2") : 322230-00400, L = 30 mm (1.18 in.)

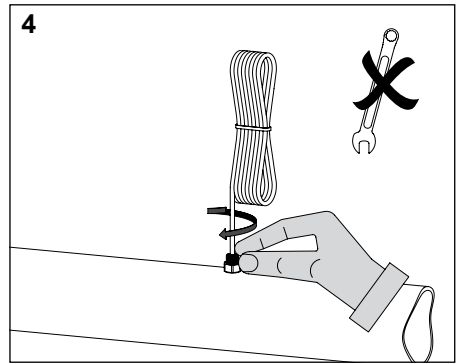
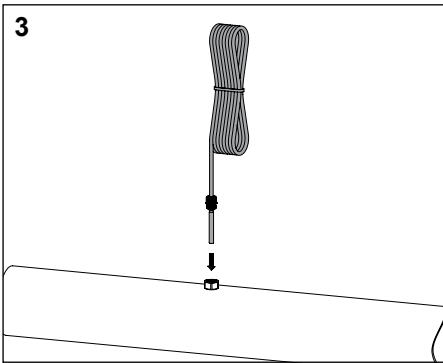
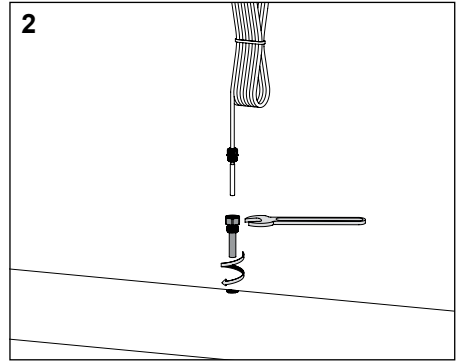
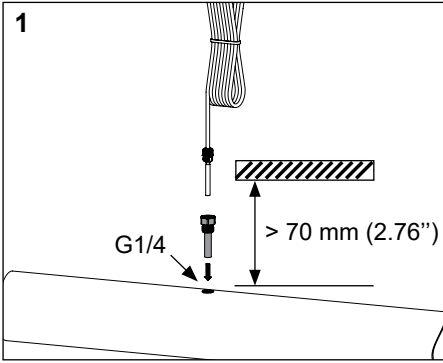

Pipe/管道 DN (in. size) (DIN 2440, ISO 65)	L	Lt	D
15-25 (1/2"-1")	<15 mm <0.59 in.	<15 mm <0.59 in.	G1/4
32-50 (1 1/4" - 2")	<20 mm < 0.79 in.	<20 mm < 0.79 in.	



LiYY or similar/LiYY或类似

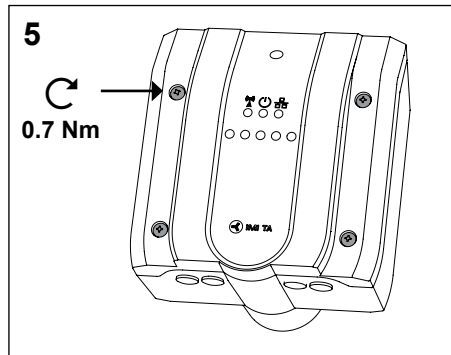
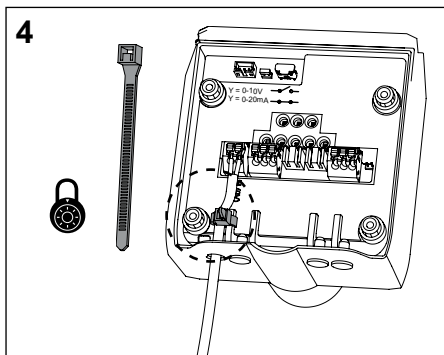
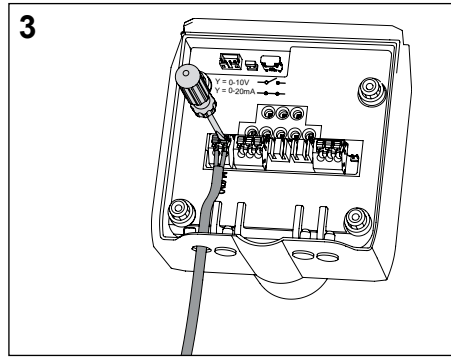
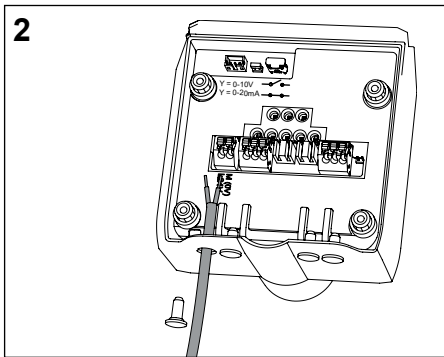
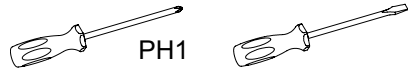
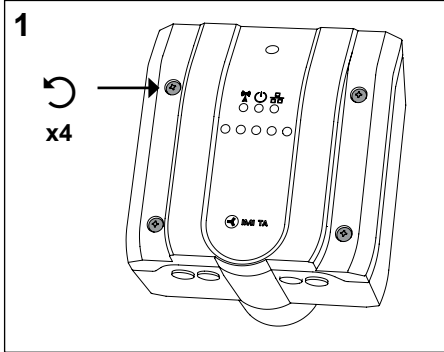
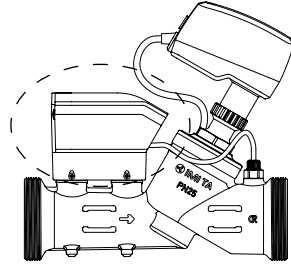
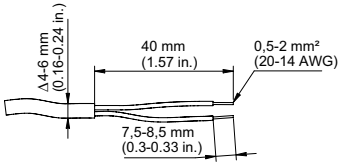

Wiring diagrams/接线图

Terminal 端子	Description 说明
L24	Power supply 24 VAC/VDC. 电源 24 VAC/VDC
M*	Neutral for power supply 24 VAC/VDC and signals. 电源 24 VAC/VDC 的中性线和信号
X _v	Output signal 0(2)-10 VDC, max. 8 mA or min. load resistance 1.25 k Ω . 输出信号 0(2)-10 VDC, 最大 8 mA 或最小负载阻抗 1.25 k Ω
M (0V)*	Neutral for signal. 信号中性点
Y	Input signal 0(2)-10 VDC, 47 k Ω or 0(4)-20 mA, 500 Ω (selectable by jumper XX). 输入信号 0(2)-10 VDC, 47 k Ω 或 0(4)-20 mA, 500 Ω (可通过跳线 XX 选择)。
Ethernet	
RX -	Ethernet connector wire position 6 以太网连接器接线位置 6
RX +	Ethernet connector wire position 3 以太网连接器接线位置 3
TX -	Ethernet connector wire position 2 以太网连接器接线位置 2
TX +	Ethernet connector wire position 1 以太网连接器接线位置 1
RS485	
A	RS485 Data +
B	RS485 Data -
M (0V)*	Neutral for signal. 信号中性点

USB Only for IMI use/仅供IMI使用

Serial Debug Only for IMI use/仅供IMI使用

*) All M terminals are internally connected./所有 M 端子均为内部连接。

HW00

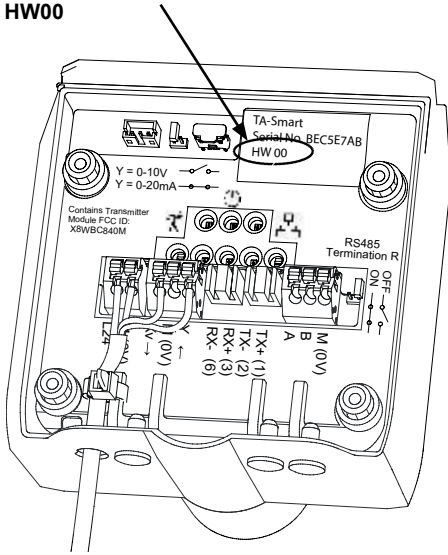

HW01

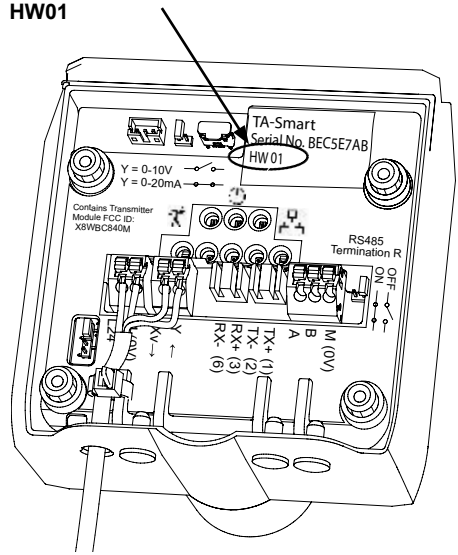

To prevent any possible damage to the product caused by incorrect cabling or wiring, we have introduced a version of the TA-Smart PCBA (HW01) with improved electrical wiring. Both PCBA versions are fully functional, but have slightly different wiring configurations. Ensure to choose the correct technical documentation based on the PCBA's HW version. The PCBA version (HW00 or HW01) can be found on the sticker in the SmartBox and the wiring instruction for each hardware version. HW00 pages 11–13 and HW01 pages 14–16.

为了防止不正确的布线或接线对产品造成任何可能的损坏，我们推出了一款改进了电线的TA-Smart PCBA (HW01)。两个版本的PCBA功能齐全，但接线配置略有不同。确保根据PCBA的硬件版本选择正确的技术文档。PCBA版本(HW00或HW01)可以在SmartBox的标签和各硬件版本的接线说明上找到。HW00在11-13页,HW01在14-16页。

HW00 (Standard - Modbus RTU / BACnet MS/TP - Modbus TCP / BACnet IP)

Standard HW00

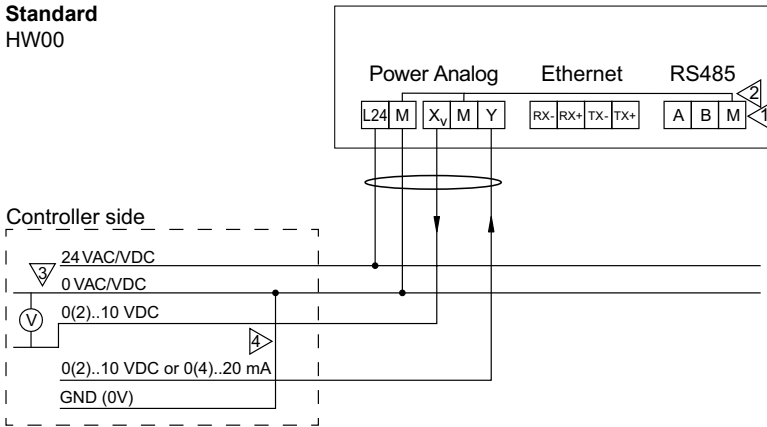

Note:

1. A, B and M terminals are NOT isolated from all other terminals.
2. GND (M - 0V) is common to power supply, analog signals and RS 485.
3. In case of AC power supply, L24 and M should be connected to the same phase for each TA-Smart.
4. GND (0V) of analog input/output should be connected to 0 VAC/VDC on the controller side.

注意:

1. A、B、M端子不与其他端子绝缘。
2. GND (M - 0V)用于电源、模拟信号和RS485。
3. 在交流供电的情况下，每台TA-Smart的L24和M应接入同相。
4. 模拟输入/输出的GND (0V)应接在控制器侧0 VAC/VDC上。



24 VAC/VDC operating only with safety isolating transformer according EN 61558-2-6.

仅依照 EN 61558-2-6 带有安全变压器时才能实现 24 VAC/VDC 运行。

Modbus RTU / BACnet MS/TP
HW00

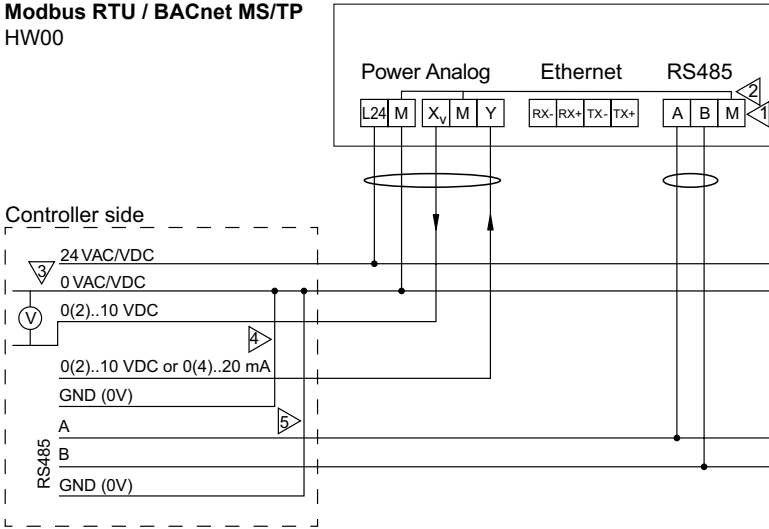

Note:

1. A, B and M terminals are NOT isolated from all other terminals.
2. GND (M - 0V) is common to power supply, analog signals and RS 485.
3. In case of AC power supply, L24 and M should be connected to the same phase for each TA-Smart.
4. GND (0V) of analog input/output should be connected to 0 VAC/VDC on the controller side.
5. GND (0V) of RS 485 should be connected to 0 VAC/VDC on the controller side.

注意:

1. A、B、M端子不与其他端子绝缘。
2. GND (M - 0V)用于电源、模拟信号和RS485。
3. 在交流供电的情况下，每台TA-Smart的L24和M应接入同相。
4. 模拟输入/输出的GND (0V)应接在控制器侧0 VAC/VDC上。
5. RS485的GND (0V)应接在控制器侧的0 VAC/VDC上。



24 VAC/VDC operating only with safety isolating transformer according to EN 61558-2-6.
仅依照 EN 61558-2-6 带有安全变压器时才能实现 24 VAC/VDC 运行。

Modbus TCP / BACnet IP
HW00

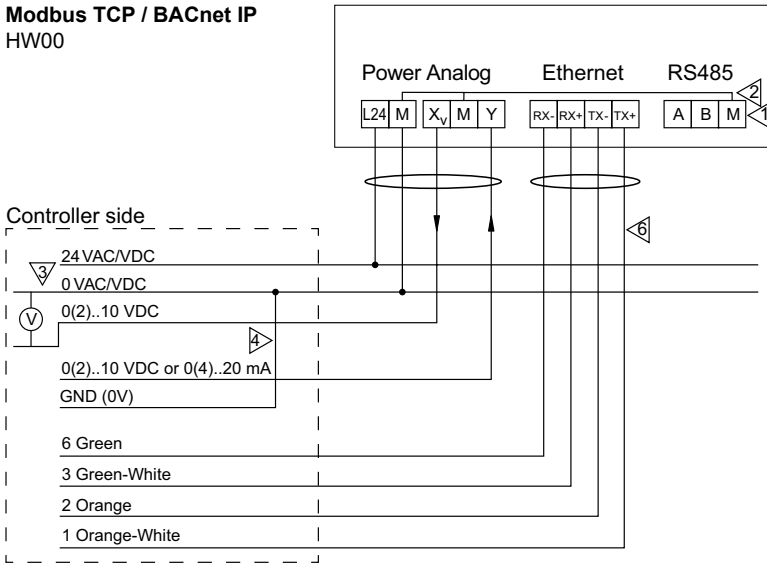

Note:

1. A, B and M terminals are NOT isolated from all other terminals.
2. GND (M - 0V) is common to power supply, analog signals and RS 485.
3. In case of AC power supply, L24 and M should be connected to the same phase for each TA-Smart.
4. GND (0V) of analog input/output should be connected to 0 VAC/VDC on the controller side.
5. Ethernet cable shall be Cat 5e or Cat 6 cable. Wire colour indication is for T568B pinout.

注意:

1. A、B、M端子不与其他端子绝缘。
2. GND (M - 0V)用于电源、模拟信号和RS485。
3. 在交流供电的情况下，每台TA-Smart的L24和M应接入同相。
4. 模拟输入/输出的GND (0V)应接在控制器侧0 VAC/VDC上。
5. 以太网电缆应为5e类或6类电缆。电线颜色指示为T568B引脚。



24 VAC/VDC operating only with safety isolating transformer according EN 61558-2-6.

仅依照 EN 61558-2-6 带有安全变压器时才能实现 24 VAC/VDC 运行。

HW01 (Standard - Modbus RTU / BACnet MS/TP - Modbus TCP / BACnet IP)

Standard

HW01

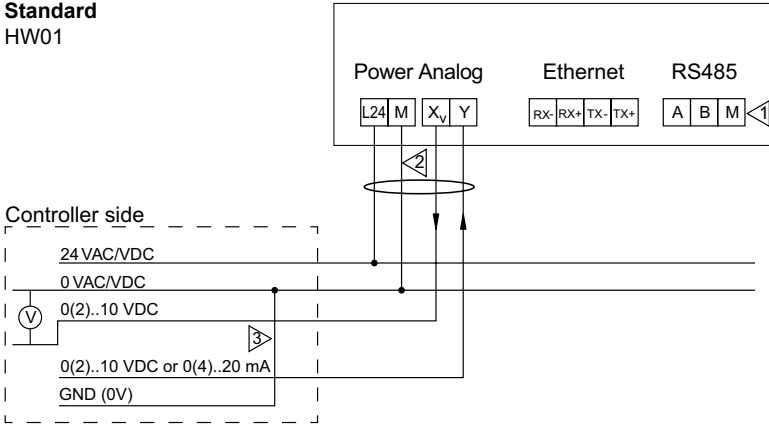

Note:

1. A, B and M terminals are isolated from all other terminals.
2. GND (M - 0V) is common to power supply and analog signals.
3. GND (0V) of analog input/output should be connected to 0 VAC/VDC on the controller side.

注意:

1. A、B、M端子与所有其他端子绝缘。
2. GND (M - 0V)用于电源和模拟信号。
3. 模拟输入/输出的GND (0V)应接在控制器侧0 VAC/VDC上。



24 VAC/VDC operating only with safety isolating transformer according EN 61558-2-6.

仅依照 EN 61558-2-6 带有安全变压器时才能实现 24 VAC/VDC 运行。

Modbus RTU / BACnet MS/TP
HW01

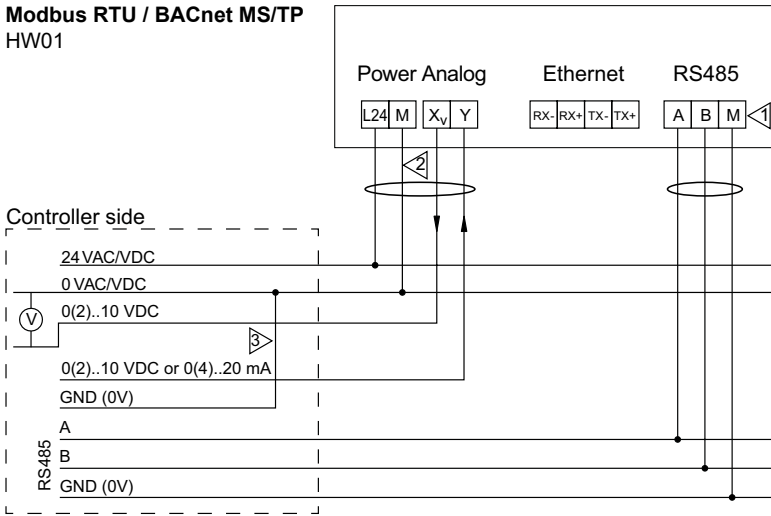

Note:

1. A, B and M terminals are isolated from all other terminals.
2. GND (M - 0V) is common to power supply and analog signals.
3. GND (0V) of analog input/output should be connected to 0 VAC/VDC on the controller side.

注意:

1. A、B、M端子与所有其他端子绝缘。
2. GND (M - 0V)用于电源和模拟信号。
3. 模拟输入/输出的GND (0V)应接在控制器侧0 VAC/VDC上。



24 VAC/VDC operating only with safety isolating transformer according EN 61558-2-6.

仅依照 EN 61558-2-6 带有安全变压器时才能实现 24 VAC/VDC 运行。

Modbus TCP / BACnet IP
HW01

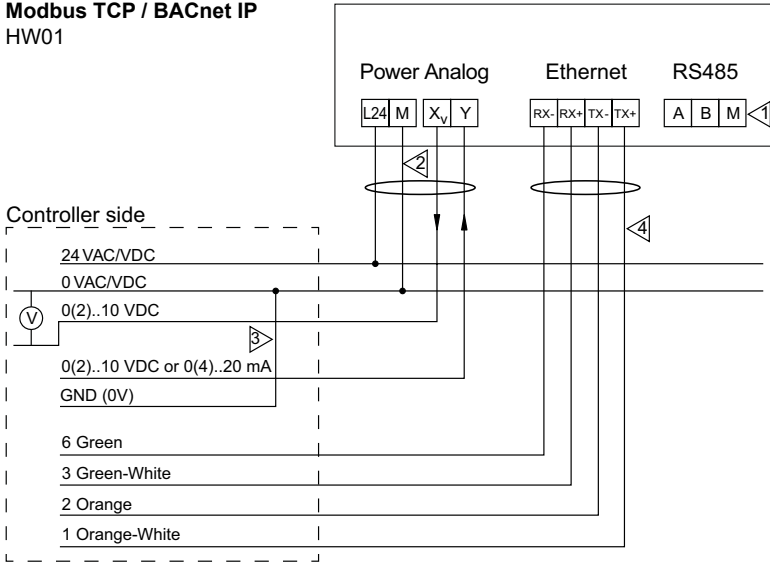

Note:

1. A, B and M terminals are isolated from all other terminals.
2. GND (M - 0V) is common to power supply and analog signals.
3. GND (0V) of analog input/output should be connected to 0 VAC/VDC on the controller side.
4. Ethernet cable shall be Cat 5e or Cat 6 cable. Wire colour indication is for T568B pinout.

注意:

1. A、B、M端子与所有其他端子绝缘。
2. GND (M - 0V)用于电源和模拟信号。
3. 模拟输入/输出的GND (0V)应接在控制器侧0VAC/VDC上。
4. 以太网电缆应为5e类或6类电缆。电线颜色指示为T568B引脚。



24 VAC/VDC operating only with safety isolating transformer according to EN 61558-2-6.
仅依照 EN 61558-2-6 带有安全变压器时才能实现 24 VAC/VDC 运行。

LED

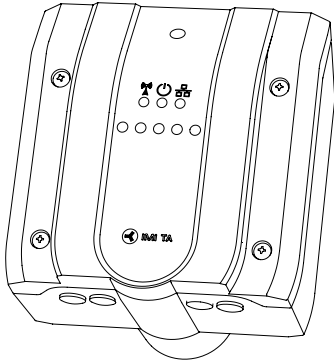

LED	Colour	Description	
⏻	Green	-----	Status OK
	Green	-----	Initiating (start up)
	Red	-----	Error (→ HyTune, Cloud, Bus)
	Off	-----	No power supply
📶	Blue	=====	Bluetooth active
	Blue	-----	Bluetooth active (no device connected)
	Off	-----	Wireless deactivated (or no power supply)
🌐	Green	=====	Ethernet connected
	Green	-----	Data being transferred (Ethernet or RS485, if Ethernet not connected)
	Off	-----	Ethernet and RS485 not connected (or no power supply)

LED	颜色	描述	
⏻	绿	-----	状态正常
	绿	-----	启动 (开始)
	红	-----	错误 (→ HyTune, Cloud, Bus)
	关闭	-----	无电源
📶	蓝色	=====	蓝牙激活
	蓝色	-----	蓝牙激活 (未连接设备)
	关闭	-----	无线停用 (或无电源)
🌐	绿	=====	以太网连接
	绿	-----	数据传输 (以太网或RS485, 如果没有连接以太网)
	关闭	-----	以太网和RS485未连接 (或无电源)

Operation 操作

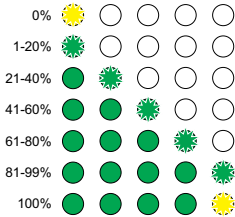

Calibration 校准

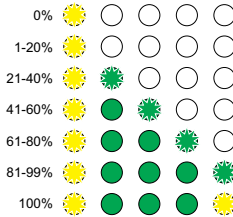

Identification 确认

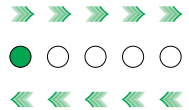

HyTune 应用程序

For setting of control parameters use HyTune app.
使用HyTune应用程序设置控制参数。

HyTune 应用程序

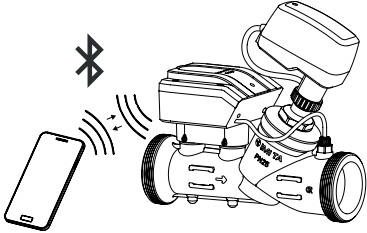

We reserve the right to introduce technical alterations without prior notice.
我们保留引进技术变更的权利，恕不另行通知。