

4000115
01.2023

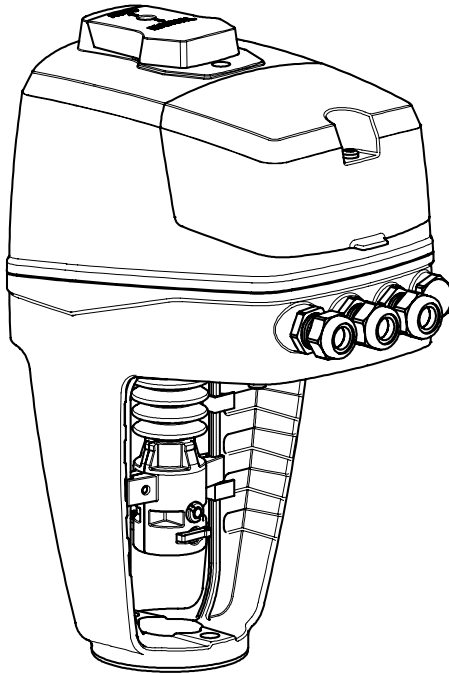

TA-Slider 750/1600 Fail-safe Plus





0°C - +50°C

32°F - +122°F

(5-95%RH, non-condensing)



0°C - +120°C

32°F - +248°F



-20°C - +70°C

-4°F - +158°F

(5-95%RH, non-condensing)



Input signal: 0-10 VDC

Output signal: 0-10 VDC

Speed: 3 s/mm (3, 4, 6, 8, 12 or 16 s/mm)

76.2 s/in (76.2, 101.6, 152.4, 203.2, 304.8 or 406.4 s/in)

Characteristic: Linear



Pollution degree 3

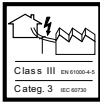

Class III EN 61000-4-5

Categ. 3 IEC 60730



EN 60730

Software
A
EN 60730

Type
1AB
EN 60730

IP54
EN 60730

TA-Slider 750/1600 Fail-safe Plus

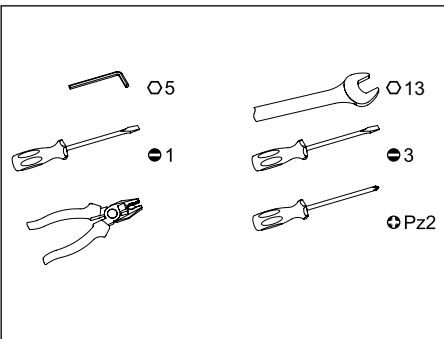
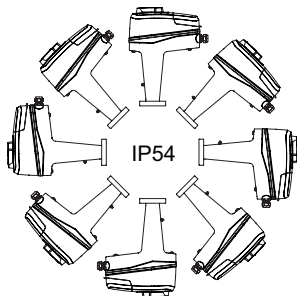
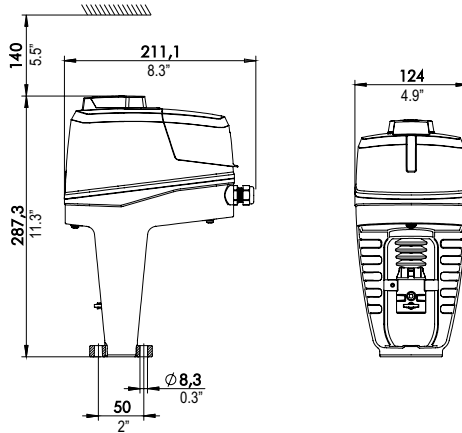

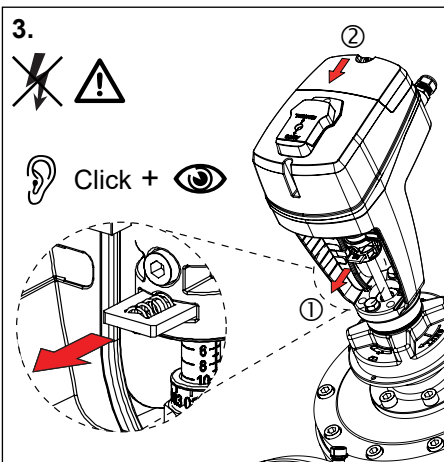
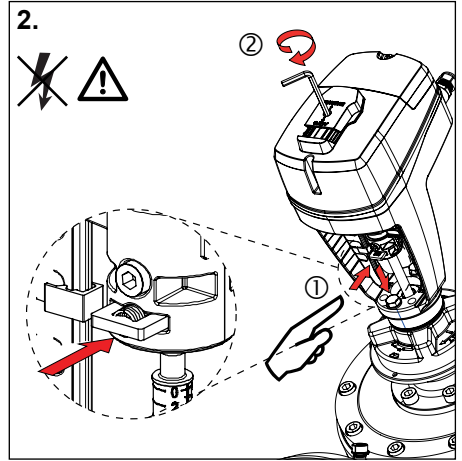
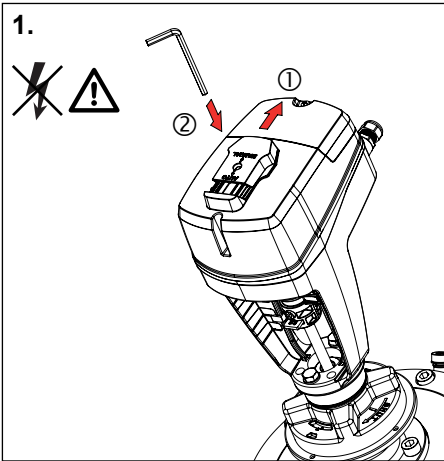
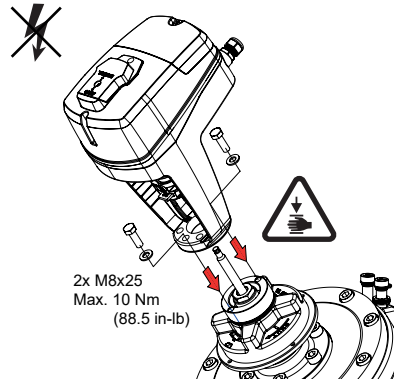
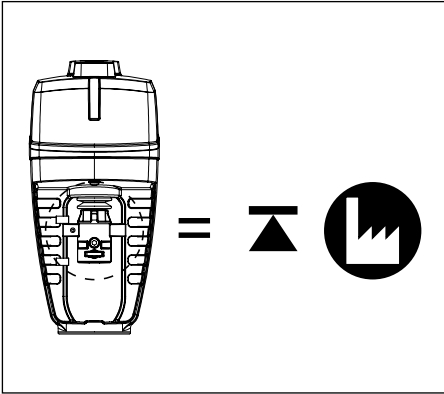

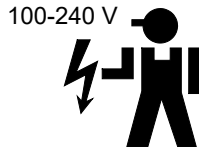
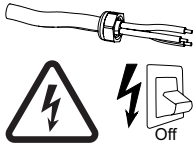

Example!

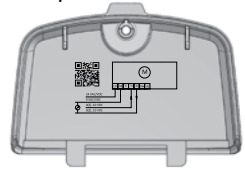

TA-Slider 750/1600 Fail-safe Plus

24 V

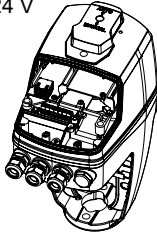

100-240 V

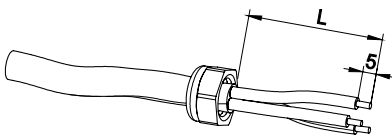
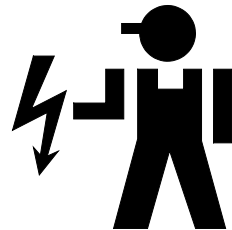
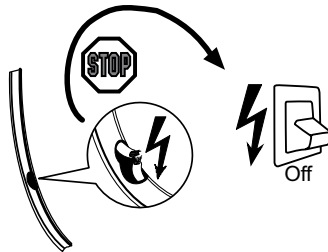
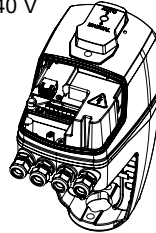

Protection class I: H05VV-F or similar
Protection class III: LiYY or similar
Wire cross-section: 0.25-2.0 mm²
(30 AWG-14 AWG)

L = 100 mm (3.94 in.)
Grounding wire L = 120 mm (4.72 in.)

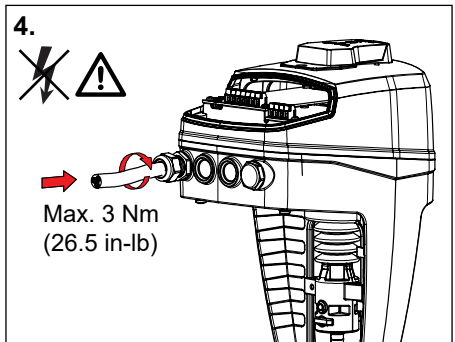
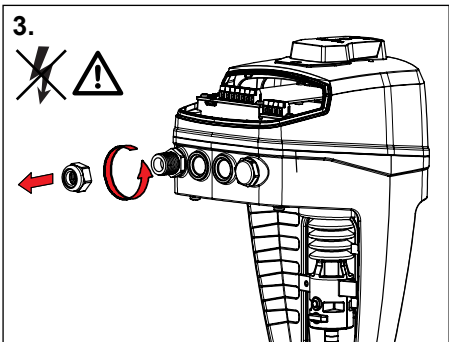
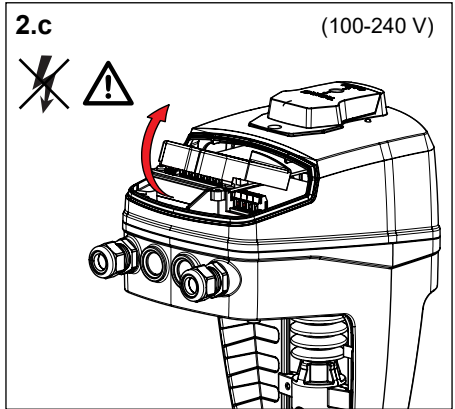
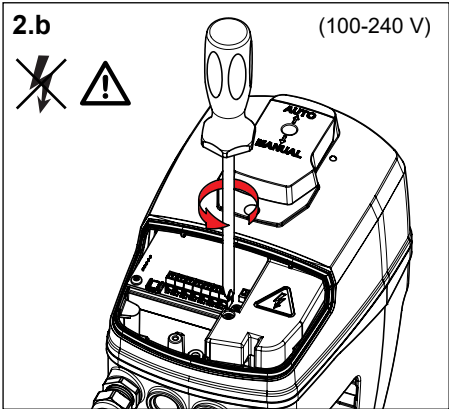
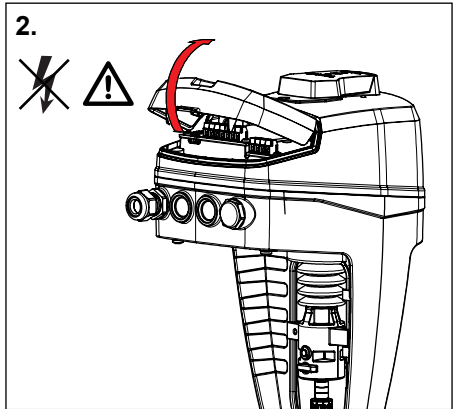
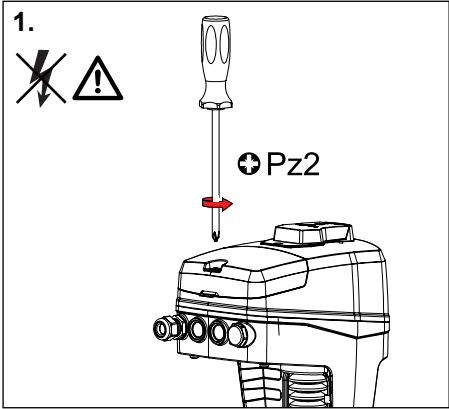

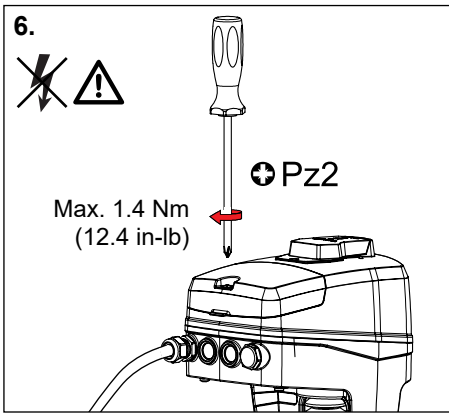
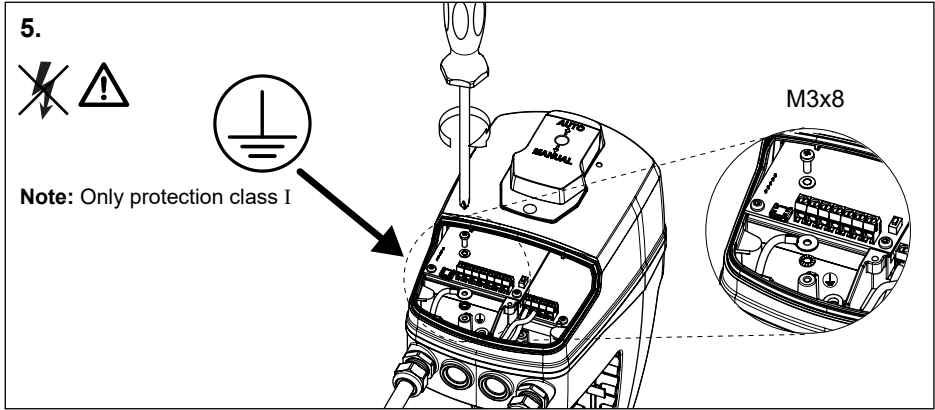

Terminal	Description
L24	Power supply 24 VAC/VDC
M*	Neutral for power supply 24 VAC/VDC and signals
L	Power supply 100-240 VAC
N	Neutral for power supply 100-240 VAC
Y _i	Input signal for proportional control 0(4)..20 mA, 500 Ω
Y _v	Input signal for proportional control 0(2)..10 VDC, 47 kΩ
X _i	Output signal 0(4)..20 mA, max. resistance 700 Ω
X _v	Output signal 0(2)..10 VDC, max. 8 mA or min. load resistance 1.25 kΩ
Dw	3-point control signal for extending actuator spindle (24 VAC/VDC or 100-240 VAC)
Up	3-point control signal for retracting actuator spindle (24 VAC/VDC or 100-240 VAC)
B	Connection for potential free contact (e.g. open window detection), max. 100 Ω, max. 10 m (32.8 ft) cable or shielded
COM1, COM2	Common contacts of relays 1 & 2, max. 250 VAC, max. 5A @ 250 VAC on resistive
NC1, NC2	Normally closed contacts for relay 1 & 2
NO1, NO2	Normally open contacts for relay 1 & 2

24 V

0(2)-10 V

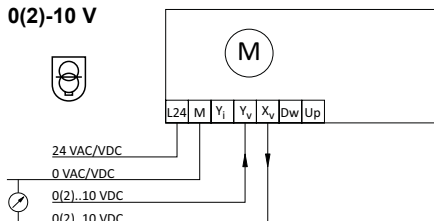

0(4)-20 mA

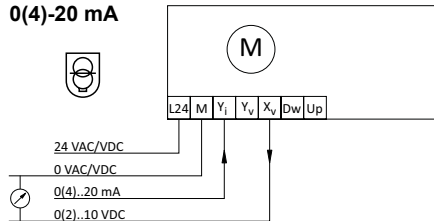

3-point

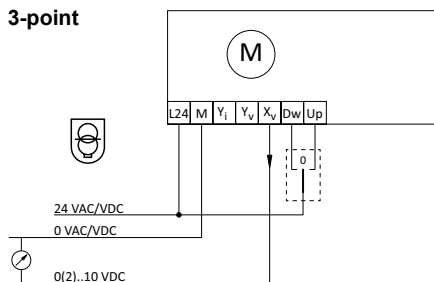

On-off

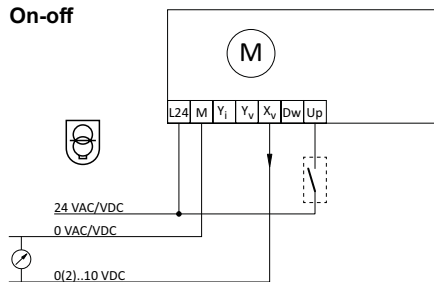

24 VAC/DC operating only with safety transformer according EN 61558-2-6

100-240 V

0(2)-10 V

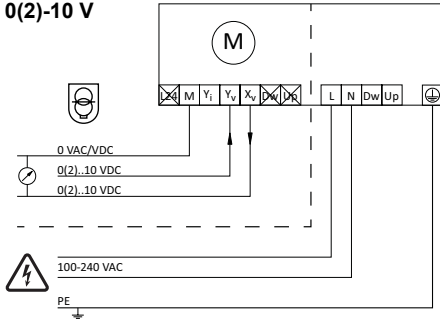

0(4)-20 mA

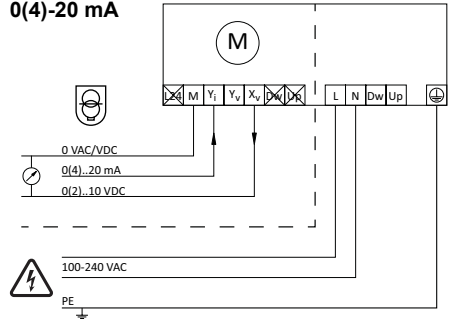

3-point

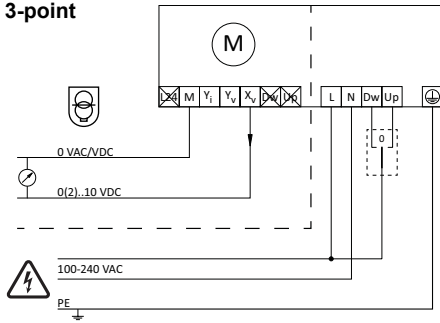

On-off

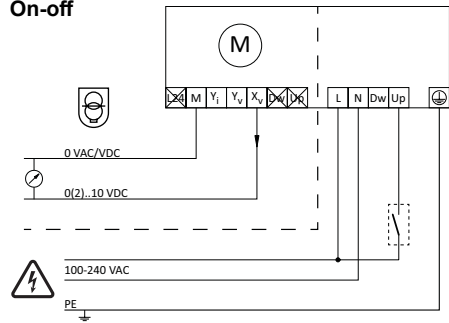

24 VAC/DC operating only with safety transformer according EN 61558-2-6

Relay

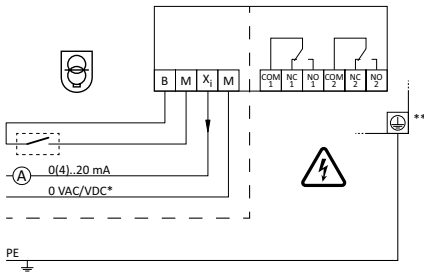

*) Low voltage neutral

**) Ground connection required.

Quick start

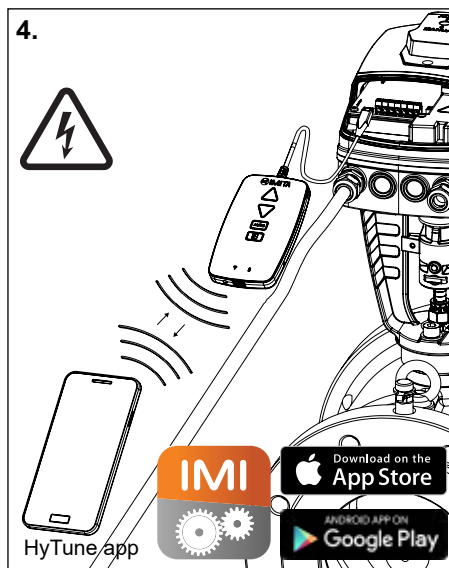
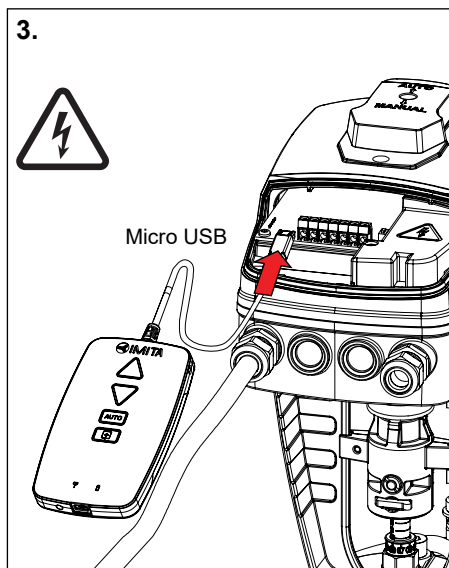
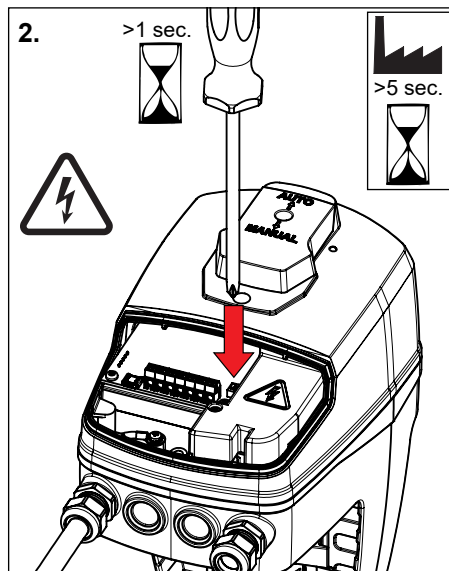
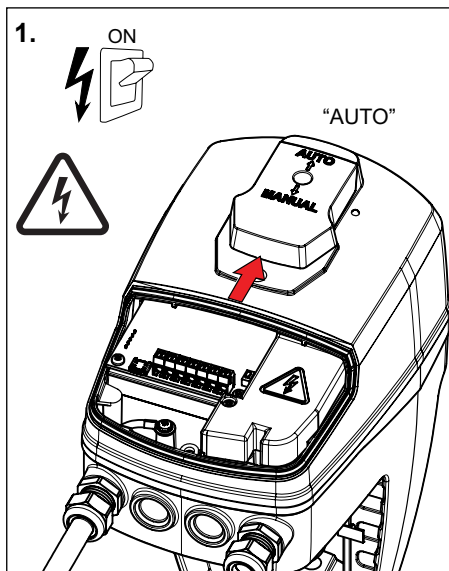

LED

GREEN

	— — — —
	— — — —
	— — — —
	— — — —
	— — — —

RED

	— — —
	— — —
	— — — —
	— — — —

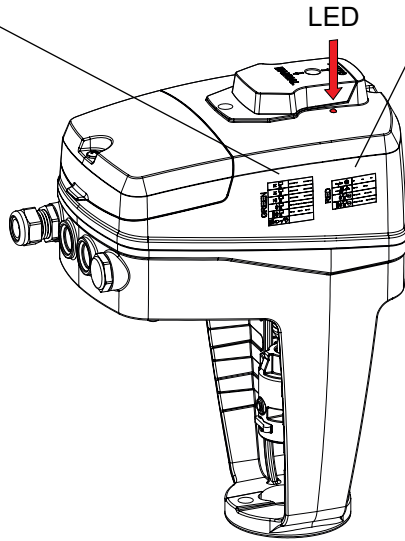

We reserve the right to introduce technical alterations without prior notice.