

TA-Slider 750/1250/1600 Modbus TCP Protocol Implementation

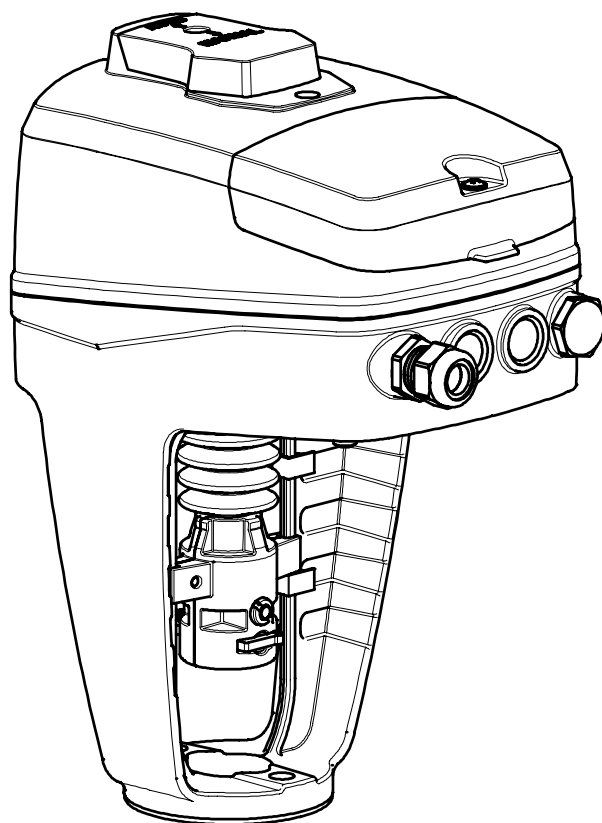

General information

Date: 21/08/2023
 Protocol: Modbus TCP
 Product Name: TA-Slider 750 Plus Modbus TCP
 TA-Slider 1250 Plus Modbus TCP
 TA-Slider 1600 Plus Modbus TCP
 Product Model Number: 322226-X421X, 322227-X421X, 322228-4221X
 Product Description: Digitally configurable proportional push-pull actuator - 750N
 Digitally configurable proportional push-pull actuator - 1250N (discontinued from 01.09.2023)
 Digitally configurable proportional push-pull actuator - 1600N
 Firmware Revision (Modbus RTU): 1.3.0
 Address: 1* to 247
 IP addressing: DHCP by default, settable with HyTune app via the TA-Dongle
 TCP port: 81 to 65535 (default: 502)
 Endianness (float): Big-endian

*) Default Value

Modbus holding registers

Register	Address	Data type	Access	Unit	Value range	Default	Description
InPos	0	Word	R/W	ym	[0-10000]	n.a	Input position
Relay ¹⁾	1	Word	R/W	n.a	0: Deactivated 1: Activated	0	Activate/Deactivate relay 1, need relay function set to Bus control (see App) ¹⁾
Relay2 ¹⁾	2	Word	R/W	n.a	0: Deactivated 1: Activated	0	Activate/Deactivate relay 2, need relay function set to Bus control (see App) ¹⁾
ForceCalib	3	Word	R/W	n.a	0: Deactivated 1: Activated	0	Request forced calibration
BusBinaryInput	4	Word	R/W	n.a	0: Deactivated 1: Activated	0	Bus binary input, use to change stroke limitation, need App configuration
FlowUnit	5	Word	R/W	n.a	0: l/h 1: GPM	0	Flow unit
Flow	8	Float	R	FlowUnit	[0.0, 3.4e+38]	0	Interpolated flow value. For this function to be active it is necessary to set the valve type in the valve section on the HyTune app.
MBSN	10	4 bytes	R	n.a	[0-2 ³²]	n.a	Actuator identification number
CurrentPos	12	Word	R	1/10%	[0-10000]	10000	Measured position expressed in tenth of percentage of the currently applicable maximum position depending on register CurrentRegime
CalibStroke	13	Word	R	µm	[0-25000] (TA-Slider 750/1250) [0-35000] (TA-Slider 1600)	n.a	Measured calibrated stroke, its value depends on the actuator type and on the mechanical pre-setting of the valve.
MotorStatus	14	Word	R	n.a	0: Stop 1: Retract 2: Extend 3: Calibration 4: Manual-override 5: Clogging 6: Error	n.a	Motor status
CurrentTime	15	Long	R	sec	[0-2 ³²]	0	Number of seconds elapsed since latest restart
Motor_OnTime	17	Long	R	sec	[0-2 ³²]	0	Total of seconds of running motor
Actuator_OnTime	19	Long	R	sec	[0-2 ³²]	0	Total of seconds of running actuator
Actuator_Distance	21	Long	R	mm	[0-2 ³²]	0	Distance traveled by the actuator spindle
BinaryInput	23	Word	R	n.a.	0: Deactivated 1: Activated	0	Status of binary input.
Relay ¹⁾	24	Word	R	n.a.	0: Deactivated 1: Activated	0	Status of Relay. Used to verify writing register 1 or to know relay status in the case of another parametrisation. ¹⁾
Relay2 ¹⁾	25		R	n.a.	0: Deactivated 1: Activated		Status of Relay2. Used to verify writing register 1 or to know relay status in the case of another parametrisation. ¹⁾
PowerType	26	Word	R	n.a.	0: None 1: AC/DC low voltage 2: AC high voltage 3: USB	1	Power type. For Modbus/BACnet, it should always be "AC/DC low voltage"
ControlCharacteristics	27	Word	R	n.a.	0: Linear 1: EQM 2: AntiEQM	0	Characteristic of the actuator. On an EQM valve it is recommended to keep a linear actuator characteristic.
Speed	28	Word	R	s/mm	[3, 16]	3	Speed of the actuator
SignalSource	29		R	n.a	1: Volt 2: Current 3: 3pts 4: OnOff 5: BusCom	1	Signal source. The BusCom is only available for bus variants of TA-Slider. It is possible to work in hybrid mode, i.e control source analog and data acquisition bus (this should be done via configuration in the HyTune mobile application).
ValveName	30	String	R	n.a	n.a	n.a	Valve name (Set by App, free text)

ObjectName	43	String	R	n.a	n.a	n.a	Object Name(Set by App, free text)
Localisation	56	String	R	n.a	n.a	n.a	Localisation (Set by App, free text)
CurErr	74	Long	R	n.a.	None = 0x00, PowerFailure = 0x01 Clogging = 0x02, StrokeDetectionFailure = 0x04, CyclicTime = 0x08, SignalOutOfRange = 0x10, OutputLineBreak = 0x20, InputLineBreak = 0x40, ResetToFactoryDefault = 0x80, SoftwareDBAccess = 0x2000, SoftwareError = 0x4000, MotorControllerError = 0x8000, ClearError = 0x80000000	0	Current error status
Errors [10]	76	Long	R	n.a.	[0-2^32]	n.a	Time in second (see current Time) reset to 0 when actuator restart
	78	Long	R	n.a.	CurErr	n.a	Current Error see error description above, cleared when Clear error flag is set
	80	Long	R	n.a.	[0-2^32]	n.a	Value (if exist data for error)
	...		R				keep up to 10 errors
	130	Long	R	n.a.	[0-2^32]	n.a	Time in second (see current Time) reset to 0 when actuator restart
	132	Long	R	n.a.	CurErr	n.a	Current Error see error description above, cleared when Clear error flag is set
	134	Long	R	n.a.	[0-2^32]	n.a	Value (if exist data for error)
CyclicControlTimeOut ³⁾	136	Word	R/W	min	[0-60]	0	Raise an error CyclicTime (0x08) if no control signal is sent before timeout
MaxPositionRegime1 ³⁾	137	Word	R/W	µm	0: Deactivated [1000 ... 22000], (TA-Slider 750/1250) [1000 ... 33000] (TA-Slider 1600)	0	Max position assigned to TA-Slider when the actuator is in regime 1
MaxPositionRegime2 ³⁾	138	Word	R/W	µm	0: Deactivated (only for reading) [1000 ... 22000], (TA-Slider 750/1250) [1000 ... 33000] (TA-Slider 1600)	0	Max position assigned to TA-Slider when the actuator is in regime 2
MinPosition ³⁾	139	Word	R/W	µm	[0...MaxPositionRegimeI]	0	Min position assigned to TA-Slider regardless of the regime

¹⁾ only with relay option

²⁾ Available from firmware version 2.0.2 (Main board: 4.0.0)

³⁾ only from firmware version 1.3.0

Wiring diagrams – Terminal/Description

Terminal	Description
L24	Power supply 24 VAC/VDC
M*	Neutral for power supply 24 VAC/VDC and signals
L	Power supply 100-240 VAC
N	Neutral for power supply 100-240 VAC
Y _i	Input signal for proportional control 0(4)..20 mA, 500 Ω
Y _v	Input signal for proportional control 0(2)..10 VDC, 47 kΩ
X _i	Output signal 0(4)..20 mA, max. resistance 700 Ω
X _v	Output signal 0(2)..10 VDC, max. 8 mA or min. load resistance 1.25 kΩ
Dw	3-point control signal for extending actuator spindle (24 VAC/VDC or 100-240 VAC)
Up	3-point control signal for retracting actuator spindle (24 VAC/VDC or 100-240 VAC)
B	Connection for potential free contact (e.g. open window detection), max. 100 Ω, max. 10 m (32.8 ft) cable or shielded
COM1, COM2	Common contacts of relays 1 & 2, max. 250 VAC, max. 5A @ 250 VAC on resistive
NC1, NC2	Normally closed contacts for relay 1 & 2
NO1, NO2	Normally open contacts for relay 1 & 2

Wiring diagrams

24 V

0(2)-10 V

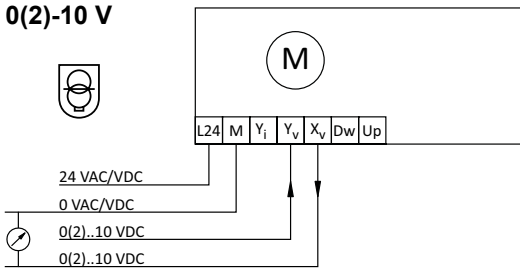

0(4)-20 mA

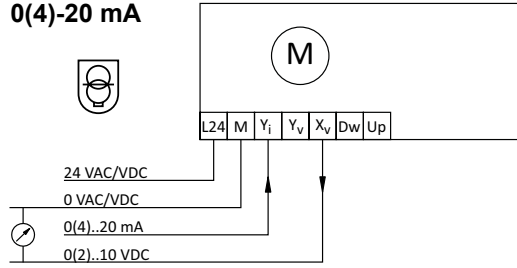

3-point

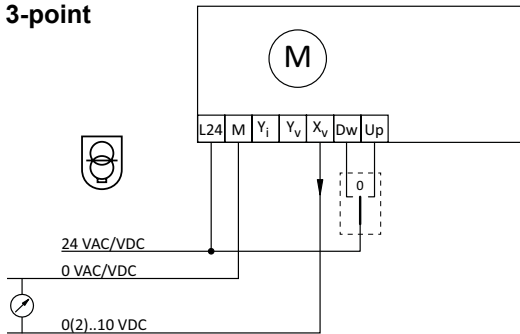

On-off

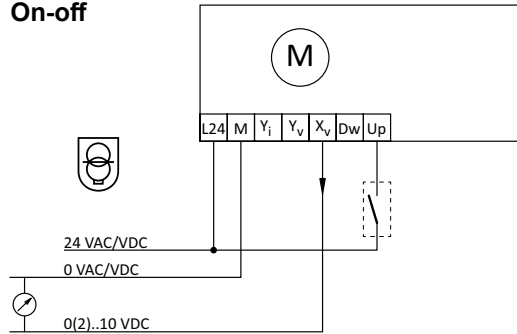

24 VAC/DC operating only with safety transformer according to EN 61558-2-6

Wiring diagrams

100-240 V

0(2)-10 V

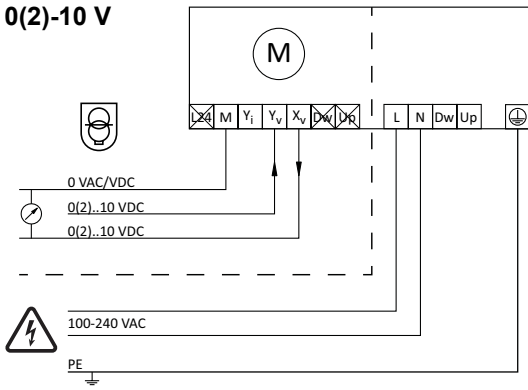

0(4)-20 mA

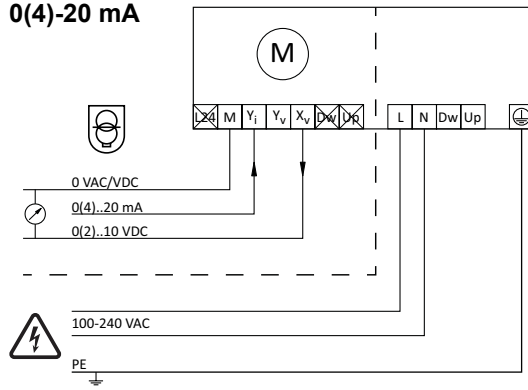

3-point

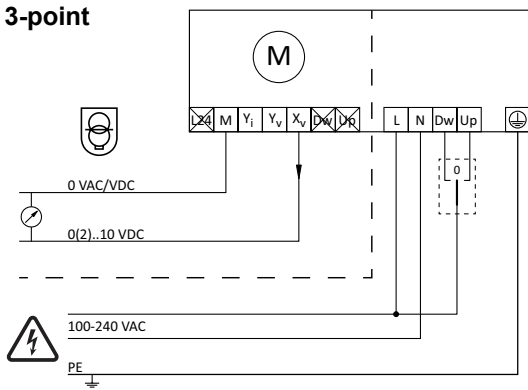

On-off

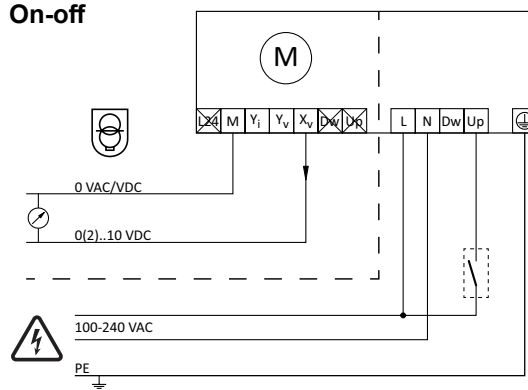

24 VAC/DC operating only with safety transformer according EN 61558-2-6

Wiring diagram

Relay (TA-Slider 750/1250/1600 Plus)

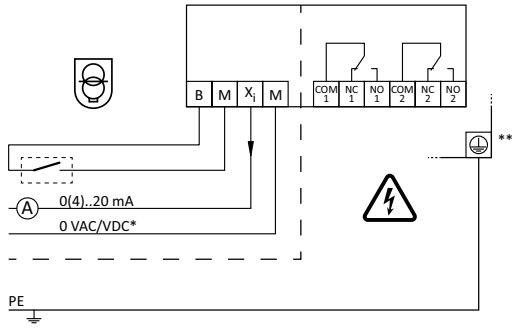

*) Low voltage neutral

***) Ground connection required.

Wiring diagram

BUS (TA-Slider 750/1250/1600 Plus)

Ethernet (BACnet/IP, Modbus/TCP)

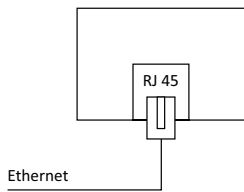

RS 485 (BACnet MS/TP, Modbus RTU)

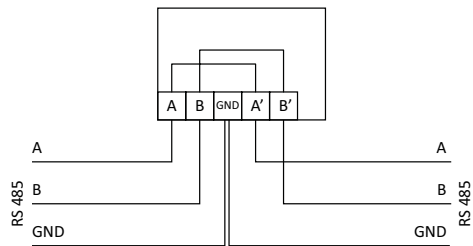
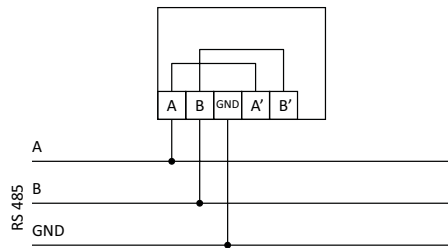

Note: A, B, A', B' and GND terminals are isolated from all other terminals.

We reserve the right to introduce technical alterations without prior notice.