

TA-Slider 750/1250/1600 BACnet IP

Protocol Implementation Conformance Statement – PICS

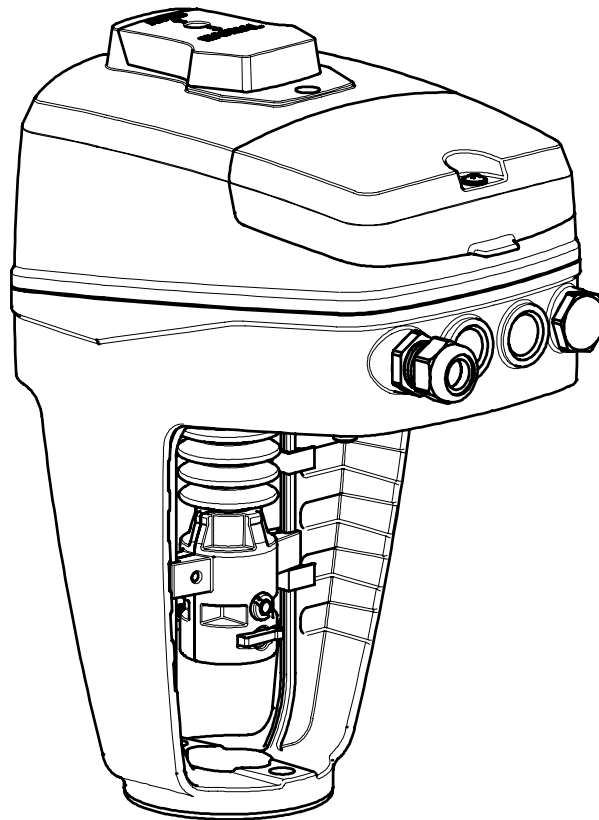

General information

Date:	29/01/2024
Vendor Name:	IMI Hydronic Engineering
Vendor ID:	926
Product Name:	TA-Slider 750 Plus BACnet IP, TA-Slider 1250 Plus BACnet IP, (discontinued from 01/09/2023) TA-Slider 1600 Plus BACnet IP
Product Model Number:	322226-X621X, 322227-X621X, 322228-X621X
Application Software:	1.2
Firmware Revision:	1.4.8
BACnet Protocol Revision:	16
Product Description:	Digitally configurable proportional push-pull actuator – 750 N, Digitally configurable proportional push-pull actuator – 1250 N, Digitally configurable proportional push-pull actuator – 1600 N, BACnet Application Specific Controller (B-ASC)
BACnet Standard Device Profile:	
BACnet interoperability Building Blocks (BIBBS)	<ul style="list-style-type: none"> • Data Sharing - ReadProperty-B (DS-RP-B) • Data Sharing - Read Property Multiple - B (DS-RPM-B) • Data Sharing - WriteProperty-B (DS-WP-B) • Data Sharing - Write Property Multiple - B (DS-WPM-B) • Device Management - DynamicDeviceBinding-B (DM-DDB-B) • Device Management - DynamicObjectBinding-B (DM-DOB-B) • Device Management - DeviceCommunicationControl-B (DM-DCC-B) * • Device Management - TimeSynchronization (DM-TS-B) **
Segmentation capability	No
Data Link Layer Options:	BACnet/IP, BACnet/IP (Foreign Device)
IP Address:	DHCP by default, settable with HyTune app via the TA-Dongle
Port:	47808 by default
Device Address Binding:	No static device binding supported
Networking Option:	None
Character Sets supported:	ISO 10646 (UTF-8)

*) No password required

**) Valid range for years is 2000 – 2099

BACnet object description

Device Objects

Object type / address	Object name	Access	Value range	Description
Device	Object ID	RW	0 ... 4194303	Value computed from the SN by default
Device	Object Name	RW	1 to 25 char	"TA-Slider 750-XXXXXXXX" or "TA-Slider 1250-XXXXXXXX" or "TA-Slider 1600-XXXXXXXX"
Device	Serial-number	R	XXXXXXXX	8 characters
Device	Max-Master	RW	1 ... 127	Maximum value for the "poll for master"
Device	Location	RW	25 char max	Empty by default
Device	Object description	R	25 char max	Valve name ("Unknown" by default)

Standard Objects

Object type / address	Object name	Access	Unit	Value range	Default	Resolution	Description
AI:0	Actual Valve position	R	%	[0.0,100.00]	n.a.	0,01	Current valve position
AI:1	Detected stroke (SI)	R	µm	[0-25000] (TA-Slider 750/1250) [0-35000] (TA-Slider 1600)	n.a.	1	Stroke detected by the calibration process (SI)
AI:2	Detected stroke US	R	in	[0 ... 0.9843] (TA-Slider 750/1250) [0 ... 1.378] (TA-Slider 1600)	n.a.	0,0001	Stroke detected by the calibration process (US)
AI:3	Motor ontime	R	s	0 ... Max uint32	n.a.	1	Actuator operation time
AI:4	Actuator ontime	R	s	0 ... Max uint32	n.a.	0,1	Actuator distance runs (US)
AI:5	Actuator distance SI	R	mm	0 ... Max uint32	n.a.	1	Actuator distance SI
AI:6	Actuator distance US	R	in	0 ... Max uint32	n.a.	0,1	Actuator distance US
AI:7	Flow SI ⁴⁾	R	l/h	[0 ... 4e9]	n.a.	1	Interpolated flow value in l/h. For this function to be active it is necessary to document the valve type in the valve section on the HyTune app.
AI:8	Flow US ⁴⁾	R	USGPM	[0 ... 4e9]	n.a.	0,0001	Interpolated flow value in USGPM. For this function to be active it is necessary to document the valve type in the valve section on the HyTune app.
AV:0	Control Value	RW	%	[0.0,100.00]	0	0,01	Relative setpoint in percentage of currently applicable max value. This setpoint applies if register ControlSource is set to Bus
AV:2	Cyclic control timeout	RW	-	[0...60] (default:0; meaning "no timeout")	0	1	Raise an error CyclicTime if no control signal sent before timeout

AV:3	Max Stroke Limitation R1 SI ⁵⁾	RW	µm	0: deactivated [1000 ... 22000] (TA-Slider 750/1250) [1000 ... 33000] (TA-Slider 1600)	0	1	Max position in µm assigned to TA-Slider when the actuator is in regime 1
AV:4	Max Stroke Limitation R1 US ⁵⁾	RW	in	0: deactivated [0.0394 ... 0,8661] (TA-Slider 750/1250) [0.0394 ... 1,2992] (TA-Slider 1600)	0	0,0001	Max position in inches assigned to TA-Slider when the actuator is in regime 1
AV:5	Max Stroke Limitation R2 SI ⁵⁾	RW	µm	[1000 ... 22000] (TA-Slider 750/1250) [1000 ... 33000] (TA-Slider 1600)	0	1	Max position in µm assigned to TA-Slider when the actuator is in regime 2. These registers are only activable if either: - Hybrid mode is activated and dual range is selected - Binary action or bus binary action is set to ChangeLimitedStroke. These configurations are to be set with the HyTune mobile application.
AV:6	Max Stroke Limitation R2 US ⁵⁾	RW	in	[0.0394 ... 0,8661] (TA-Slider 750/1250) [0.0394 ... 1,2992] (TA-Slider 1600)	0	0,0001	Max position in inches assigned to TA-Slider when the actuator is in regime 2. These registers are only activable if either: - Hybrid mode is activated and dual range is selected - Binary action or bus binary action is set to ChangeLimitedStroke. These configurations are to be set with the HyTune mobile application.
AV:7	Min stroke limitation SI	RW	µm	[0...MaxPositionRegimeI_SI]	0	1	Min position in µm assigned to TA-Slider regardless of the regime
AV:8	Min stroke limitation US	RW	in	[0...MaxPositionRegimeI_US]	0	0,0001	Min position in in assigned to TA-Slider regardless of the regime
AV:10	Errors code	R	n.a.	[0...127]	0	1	Errors code (0 means "No error")
AV:11	Error 1	R	n.a.	[-7..8]	0	1	Oldest error log ³⁾
AV:12	Error 2	R	n.a.	[-7..8]	0	1	Error log ³⁾
AV:13	Error 3	R	n.a.	[-7..8]	0	1	Error log ³⁾
AV:14	Error 4	R	n.a.	[-7..8]	0	1	Error log ³⁾
AV:15	Error 5	R	n.a.	[-7..8]	0	1	Error log ³⁾
AV:16	Error 6	R	n.a.	[-7..8]	0	1	Error log ³⁾
AV:17	Error 7	R	n.a.	[-7..8]	0	1	Error log ³⁾
AV:18	Error 8	R	n.a.	[-7..8]	0	1	Error log ³⁾
AV:19	Error 9	R	n.a.	[-7..8]	0	1	Error log ³⁾
AV:20	Error 10	R	n.a.	[-7..8]	0	1	Newest error log ³⁾
Bl:0	Forced position	R	n.a.	0: No 1: Yes	No	n.a.	Indicate if mechanical or electrical override
Bl:1	Binary Input ¹⁾	R	n.a.	0: Off 1: On	Off	n.a.	Binary input state
BV:0	Valve opening type	R	n.a.	0: Push to close 1: Push to Open	Push to close	n.a.	Valve direction of the input signal
BV:1	Force calibration ²⁾	RW	n.a.	0: Off 1: On	Off	n.a.	Request forced calibration
BV:2	Bus Binary input	RW	n.a.	0: Off 1: On	Off	n.a.	Bus binary input, use to change stroke limitation, need App configuration
BV:3	Relay ¹⁾	[RW]	n.a.	0: Deactivated 1: Activated	Deactivated	n.a.	Activate/Deactivate relay 1, need relay function set to Bus control (see App) ¹⁾
BV:4	Relay ²⁾	[RW]	n.a.	0: Deactivated 1: Activated	Deactivated	n.a.	Activate/Deactivate relay 1, need relay function set to Bus control (see App) ¹⁾
BV:5	Enable Limited Stroke	[RW]	n.a.	0: Deactivated 1: Activated	Deactivated	n.a.	This value is read-only if the change-over switching type has been defined with physical binary input or dual -range in the HyTune app.
MSI:0	Motor status	R	n.a.	1: Stop 2: Retract 3: Extend 4: Calibration 5: Manual-override 6: Clogging 7: Error	1	n.a.	Motor status.
MSI:1	Power type	R	n.a.	1: Low 2: High 3: USB	n.a.	n.a.	Power type.

MSI:2	Characteristic	R	n.a.	1: Linear, 2: Equal Percentage Modified (EQM), 3: Inverted EQM	n.a.	n.a.	Characteristic of the actuator. On an EQM valve it is recommended to keep a linear actuator characteristic.
MSI:3	Speed	R	s/mm	3 s/mm; 75 s/inch, 4 s/mm; 100 s/inch, 6 s/mm; 150 s/inch, 8 s/mm; 200 s/inch, 12 s/mm; 300 s/inch, 16 s/mm; 400 s/inch	n.a.	n.a.	Speed of the actuator, it is parametrisable via the HyTune mobile application

- 1) Only with relay option.
- 2) Force calibration object value is only raised to "On" while a forced calibration is taking place. Object goes back to value "Off" upon completion of the forced calibration.
- 3) Timestamp of the error and short error description.
- 4) Available from firmware version 1.1.0 (Main board: 4.0.0)
- 5) Available from firmware version 1.3.0

Object processing

Object Type	Optional properties	Writable properties
Analog Input	Min Pres Value Max Pres Value	Present Value Out of Service
Analog Value	Description Min Pres Value	Present Value Out of Service
Binary Input	Inactive Text Active Text	Present Value Out of Service
Binary Value	Inactive Text Active Text	Present Value Out of Service
Device	Location Description Local Time Locat Date Serial Number	Object Identified Object Name Location
Multi-State Input	State Text	Present Value Out of Service

The properties Object name and Location of the Device Object support up to 25 characters (all other character strings are read-only).
The device does not support the CreateObject and DeleteObject service.

Wiring diagrams – Terminal/Description

Terminal	Description
L24	Power supply 24 VAC/VDC
M*	Neutral for power supply 24 VAC/VDC and signals
L	Power supply 100-240 VAC
N	Neutral for power supply 100-240 VAC
Y _i	Input signal for proportional control 0(4)..20 mA, 500 Ω
Y _v	Input signal for proportional control 0(2)..10 VDC, 47 kΩ
X _i	Output signal 0(4)..20 mA, max. resistance 700 Ω
X _v	Output signal 0(2)..10 VDC, max. 8 mA or min. load resistance 1.25 kΩ
Dw	3-point control signal for extending actuator spindle (24 VAC/VDC or 100-240 VAC)
Up	3-point control signal for retracting actuator spindle (24 VAC/VDC or 100-240 VAC)
B	Connection for potential free contact (e.g. open window detection), max. 100 Ω, max. 10 m (32.8 ft) cable or shielded
COM1, COM2	Common contacts of relays 1 & 2, max. 250 VAC, max. 5A @ 250 VAC on resistive
NC1, NC2	Normally closed contacts for relay 1 & 2
NO1, NO2	Normally open contacts for relay 1 & 2

Wiring diagrams

24 V

0(2)-10 V

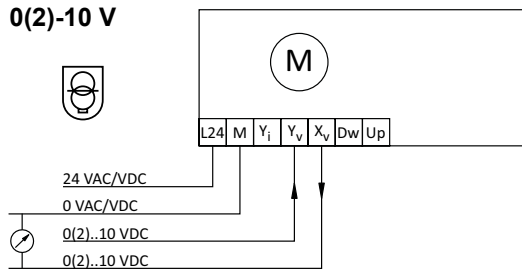

0(4)-20 mA

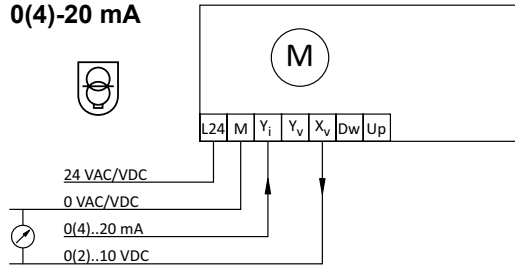

3-point

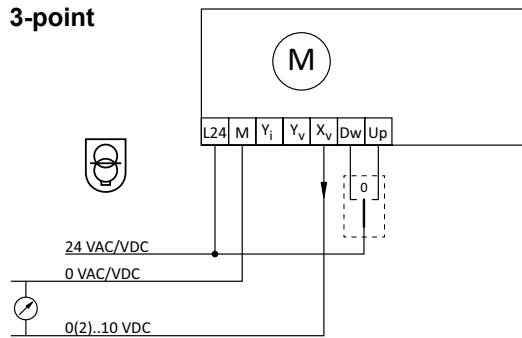

On-off

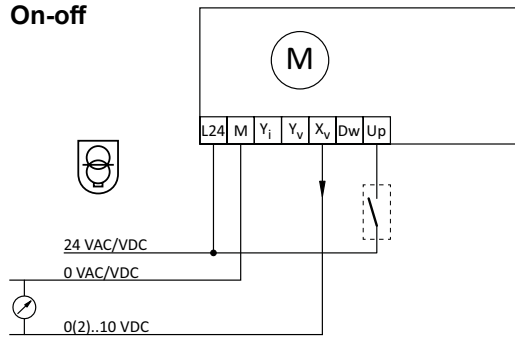

Wiring diagrams

100-240 V

0(2)-10 V

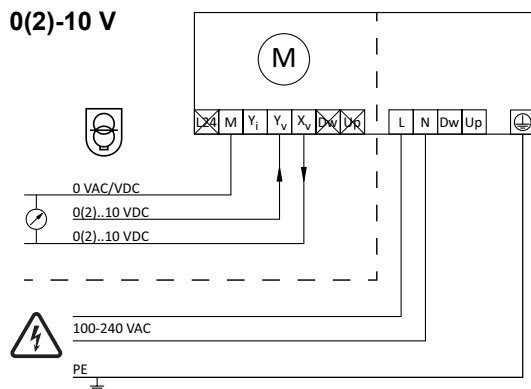

0(4)-20 mA

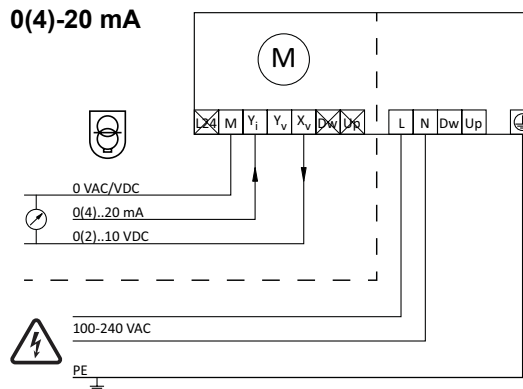

3-point

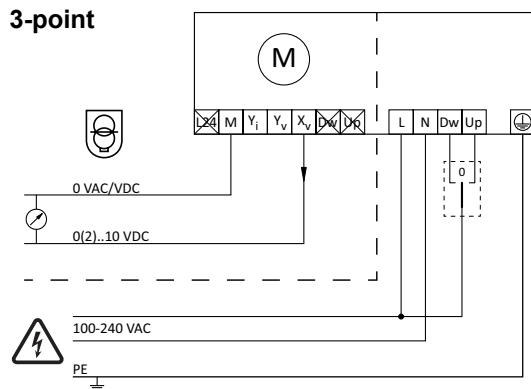

On-off

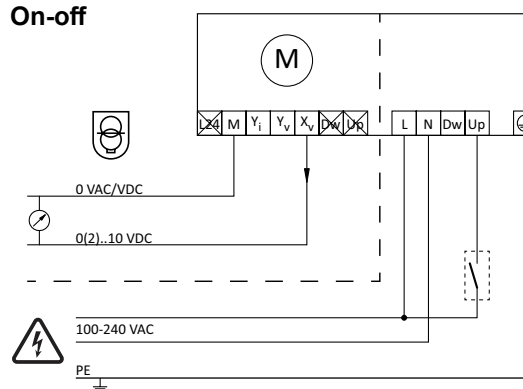

24 VAC/DC operating only with safety transformer according EN 61558-2-6

Wiring diagram

Relay (TA-Slider 750/1250/1600 Plus)

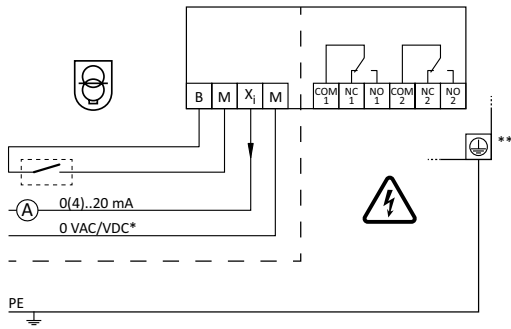

*) Low voltage neutral

***) Ground connection required.

Wiring diagram

BUS (TA-Slider 750/1250/1600 Plus)

Ethernet (BACnet/IP, Modbus/TCP)

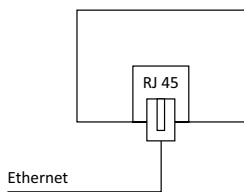

RS 485 (BACnet MS/TP, Modbus RTU)

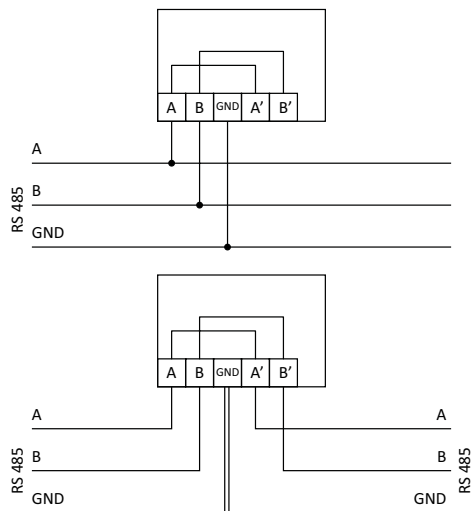

Note: A, B, A', B' and GND terminals are isolated from all other terminals.

We reserve the right to introduce technical alterations without prior notice.