

TA Fast-Fit with internal NPT threads

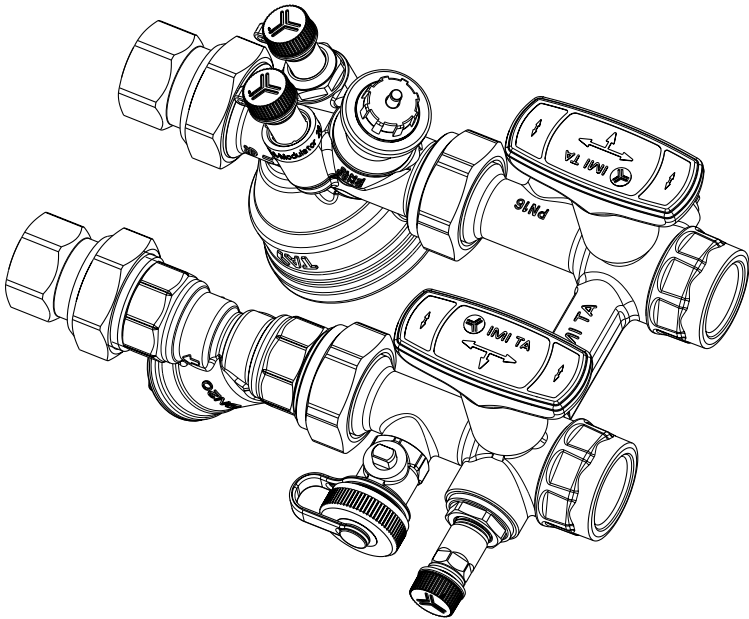

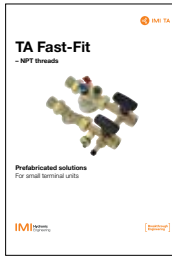

www.imi-hydraulic.com

TA-Modulator/TA-COMPACT-P

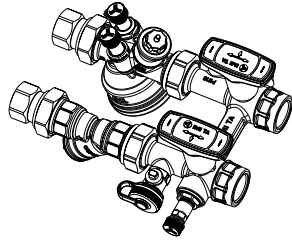

NOTE! Assembly example, product components may vary.

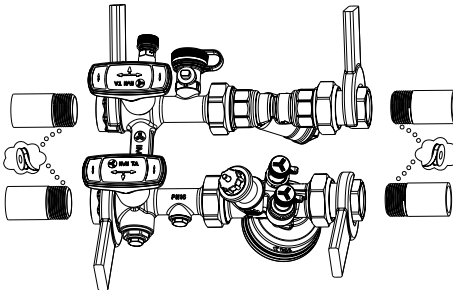
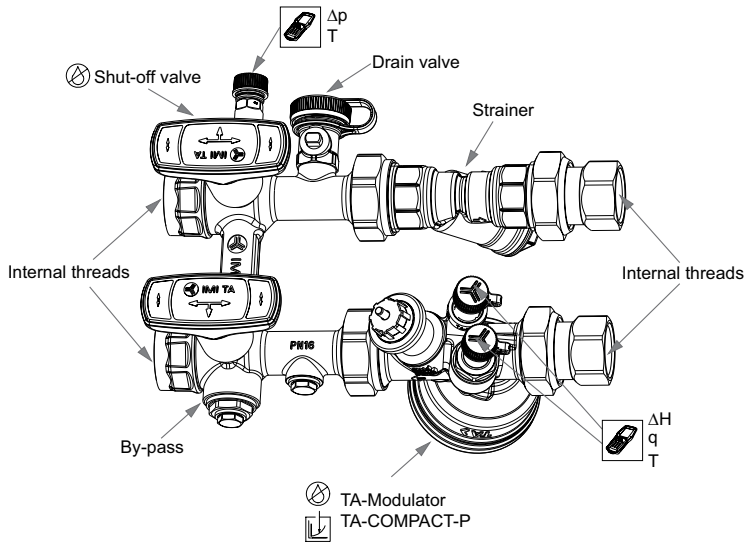

NOTE!

It is not allowed to hold the TA Fast-Fit assembly, during installation, on other places then indicated by the wrenches in the illustration.

Max. torque \leq 36.9 lbf.ft. (50 Nm)

EMO T / EMO TM

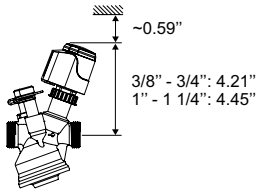

TA-Slider 160

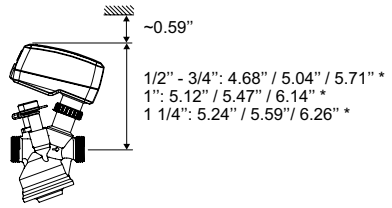

*) Height depending on actuator version.

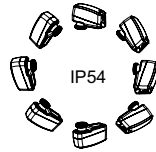
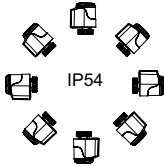

Normal operation

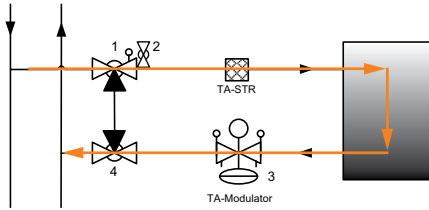

1. Open
2. Closed
3. Open
4. Open

Back flushing

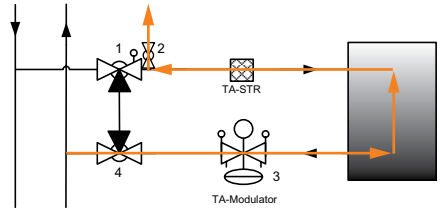

1. Closed
2. Open
3. Open
4. Open

Flushing the distribution system

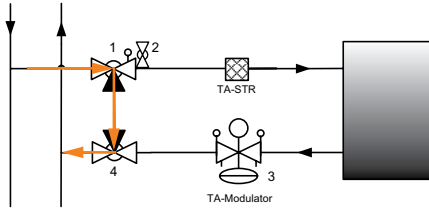

1. Closed
2. Closed
3. Open
4. Closed

Forward flushing

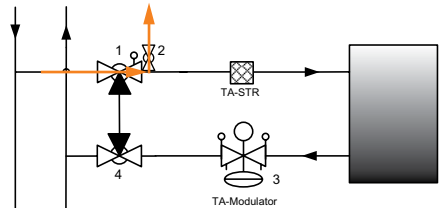

1. Open
2. Open
3. Closed
4. Open

Open

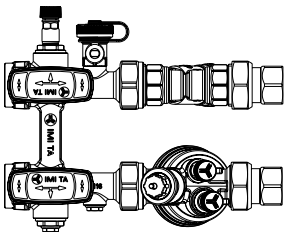

Closed

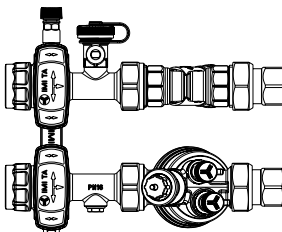

Flushing the distribution system

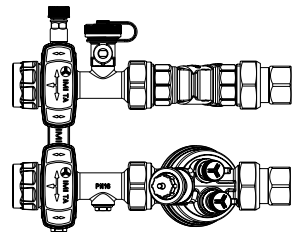

TA-Modulator / TA-COMPACT-P

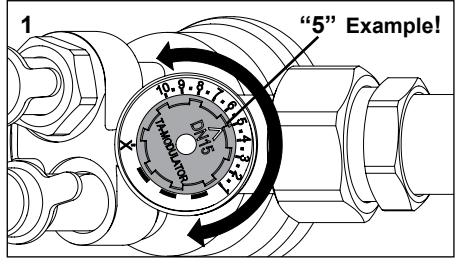
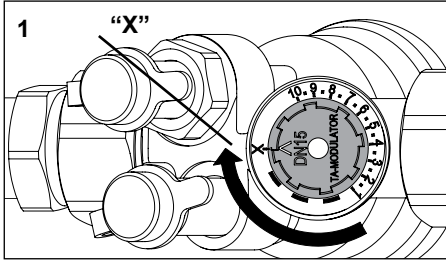
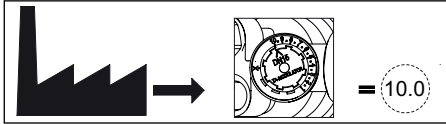

q

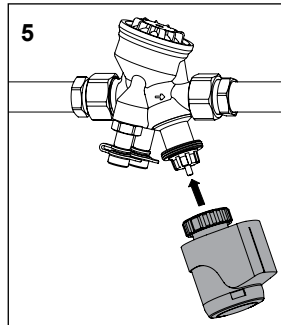
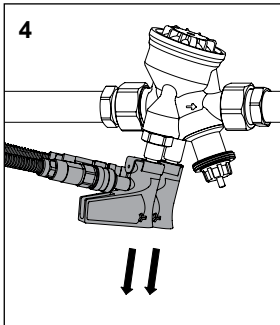
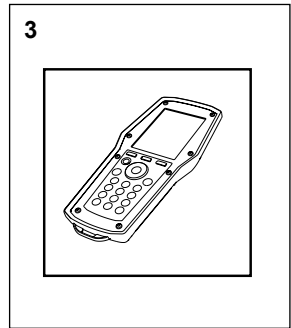
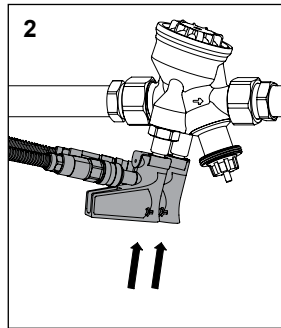
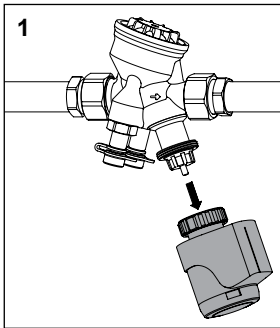

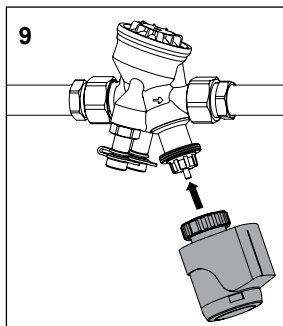
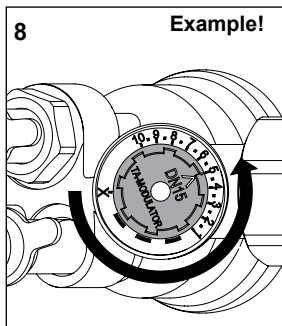
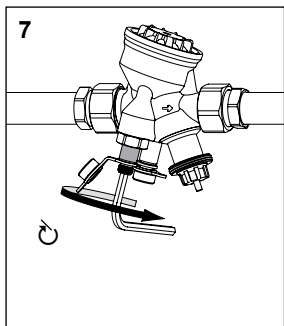
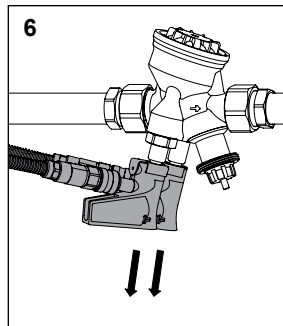
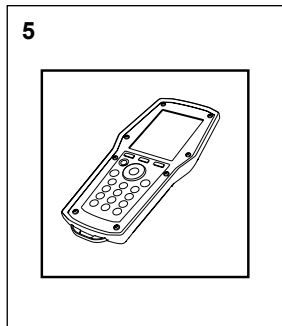
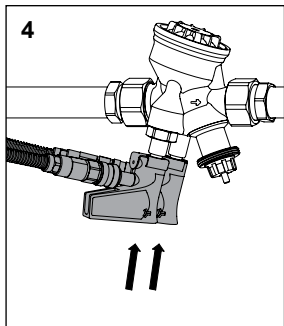
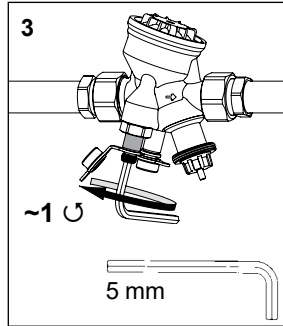
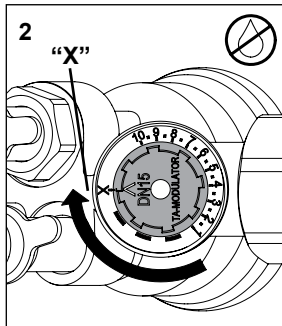
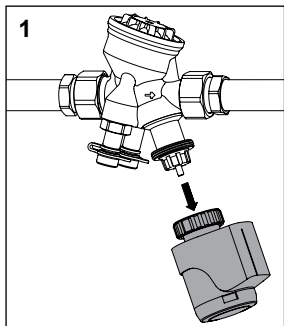

We reserve the right to introduce technical alterations without prior notice.