

TA-Smart

- NPT threads/ANSI flanges



Smart valves

2-way control valve with uniquely shaped EQM characteristics with flow, temperature and power measurement capabilities

TA-Smart

– NPT threads/ANSI flanges

The ultrasonic flow measurement technology combined with unique actuation algorithms capabilities provide best-in-class control performances. The TA-Smart controls can be set to flow or power, giving high on-site flexibility and providing highly effective comfort in heating and cooling applications. Its compact arrangement and simple set-up reduces installation and commissioning time.



Key features

- > **Best-in-class control**
Accurate and fast control response even at very low flows in common part load conditions. Ensures full modulating control for the complete operating stroke leading to world class control and efficiencies.
- > **Optional cloud connection**
Easy remote access to data and configuration parameters allows to verify and adjust system performance.
- > **Optional ΔT and temperature return limitation**
Optimize the efficiency of your production units by ensuring optimal temperature regimes.
- > **Change-over functionality**
Possibility to switch between two operating conditions to manage seasonality or heating and cooling with the same valve in change-over applications.
- > **High measurement accuracy**
High flow and temperature measurement accuracies in all configurations (medium type, and temperature) for all flow regimes.
- > **Compactness and limited number of components**
Reduces installation time and space requirements facilitating retrofit installation.
- > **Convenient, reliable setup**
Fully customizable and commissionable using Bluetooth enabled smart device reducing commissioning and diagnostic time.
- > **Easy diagnostics**
Continuous measurement (flow, temperature, power...) enables accurate error identification in system hydraulics.
- > **Versatility in communication**
Digital (key Bus protocols and MQTT) and Analog (0(2)-10 VDC or 0(4)-20 mA).

Technical description

Application:

Heating and cooling systems.

Functions:

Control (flow, power, position)
Pre-setting (max./min. flow, max. power, max./min. position)
 ΔT and temperature return limitation
Reading (flow, power, energy, supply/return temperature, ΔT , position)
Change-over function
Manual override (via HyTune app)
Mode, status and position indication
Valve blockage protection
Valve clogging detection
Error safe position
Diagnostic
Logging
Delayed start-up

Dimensions:

DN 15-125

Pressure class:

DN 15-50: PN 25
DN 65-125: PN 16, PN 25

Differential pressure (ΔpV):

Max. differential pressure (ΔpV_{max}):
400 kPa = 4 bar
Closing pressure: 600 kPa = 6 bar
 ΔpV_{max} = The maximum allowed pressure drop over the valve to fulfill all stated performances.

Flow range:

The flow ranges (q_{setmin} - q_{nom}) for different dimensions:

DN 15: 160 - 1200 l/h
DN 20: 380 - 1900 l/h
DN 25: 540 - 2700 l/h
DN 32: 920 - 4600 l/h
DN 40: 1560 - 7800 l/h
DN 50: 2680 - 13400 l/h
DN 65: 5800 - 29000 l/h
DN 80: 8640 - 43200 l/h
DN 100: 14200 - 71000 l/h
DN 125: 22400 - 112000 l/h
Minimum controllable flows ($q_{contr.min}$)
DN 15 0.33% of q_{nom} ; DN 20-125 0.5% of q_{nom} .
 q_{setmin} = Minimum settable flow.
 q_{nom} = Maximum settable flow.

Measurement accuracy:

Flow:

Water: From 2% accuracy at 100% of q_{nom} to 2.4% accuracy at 5% of q_{nom} (according MID-Class 2 EN1434).

Water+glycol: From 3% accuracy at 100% of q_{nom} to 4% accuracy at 5% of q_{nom} (according to MID-Class 3 EN1434). (see "Flow accuracy")

Temperature difference:

± 0.1 K @ $\Delta T = 6$ K (for cooling)

± 0.15 K @ $\Delta T = 10$ K (for heating)

± 0.2 K @ $\Delta T = 20$ K (for heating)

Flow control accuracy:

$\pm 5\%$ from 4% to 100% of q_{nom}

$\pm 10\%$ from 0.5% to 4% of q_{nom}

Temperature:

Max. working temperature: 110°C

Min. working temperature: -10°C

Operating environment: 0°C – +50°C (5-95%RH, non-condensing)

Storage environment: -20°C – +70°C (5-95%RH, non-condensing)

Media:

Water or neutral fluids, water-glycol mixtures (0-57%).

Leakage rate:

DN 15-50: Leakage rate <0.01% of q_{nom} with correct flow direction (Class IV according to EN 60534-4)

DN 65-125: Tight sealing with correct flow direction (Class V according to EN 60534-4)

Characteristics:

Settable: Stepless between EQM 0.25 and inverted EQM 0.25.

Supply voltage:

24 VAC/VDC $\pm 15\%$.

Frequency 50/60 Hz ± 3 Hz.

NOTE: 24 VAC/VDC power supply must be provided only with safety isolating transformer according to EN 61558-2-6.

Power consumption:

DN 15-50:

Operation: < 4.0 W (24 VDC);

< 5.6 VA (24 VAC)

Standby: < 1.9 W (24 VDC);

< 3.3 VA (24 VAC)

DN 65-80:

Operation: < 5.8 W (24 VDC);

< 10 VA (24 VAC)

Standby: < 1.9 W (24 VDC);

< 3.3 VA (24 VAC)

DN 100-125:

Operation: < 7.7 W (24 VDC);

< 10.8 VA (24 VAC)

Standby: < 1.9 W (24 VDC);

< 3.3 VA (24 VAC)

Input signal:

By BACnet/Modbus or Analog signal.

Analog in VDC or mA, selectable by jumper in the SmartBox;

0(2)-10 VDC, R_i 47 k Ω .

Adjustable sensitivity 0.1-0.5 VDC.

0.33 Hz low pass filter.

0(4)-20 mA R_i 500 Ω .

Proportional:

0-10, 10-0, 2-10 or 10-2 VDC.

0-20, 20-0, 4-20 or 20-4 mA.

Proportional split-range:

0-5, 5-0, 5-10 or 10-5 VDC.

0-4.5, 4.5-0, 5.5-10 or 10-5.5 VDC.

2-6, 6-2, 6-10 or 10-6 VDC.

0-10, 10-0, 10-20 or 20-10 mA.

4-12, 12-4, 12-20 or 20-12 mA.

Proportional dual-range (for change-over):

0-4.5 / 5.5-10 VDC.

2-5.5 / 6.5-10 VDC.

0-3.3 / 6.7-10 VDC.

2-4.7 / 7.3-10 VDC.

0-9 / 11-20 mA.

4-11 / 13-20 mA.

Default setting: Proportional 0-10 VDC.

Output signal:

BACnet/Modbus

0(2)-10 VDC, max. 8 mA, min. 1.25 k Ω .

Wireless:

Bluetooth Low Energy (BLE)

Thread

Temperature sensor cable:

DN 15-50: 3 m halogen free

DN 65-125: 5 m halogen free

10 m halogen free cable on request.

Ingress protection:

IP54 (according to EN 60529)

Protection class:

(according to EN 61140)

III (SELV)

Material:

DN 15-50:

Valve body: AMETAL[®]

Valve insert: AMETAL[®]

Valve plug: AMETAL[®] and PTFE

Spindle: Stainless steel

Spindle seal: EPDM O-ring

Internal plastic parts: PPS

Springs: Stainless steel

O-rings: EPDM

Temperature housing: AMETAL[®].

DN 65-125:

Valve body: Ductile iron EN-GJS-400-15

Valve insert: Ductile iron EN-GJS-400-15 and brass

Valve plug: Stainless steel and EPDM

O-ring

Valve seat: Stainless steel

Spindle: Stainless steel

Spindle seal: EPDM

Springs: Stainless steel

O-rings: EPDM

SmartBox (DN 15-125):

Cover: PC/ABS, red.

Housing: PC/ABS, TPE.

Actuators:

DN 15-50:

Cover: PC/ABS GF8, white RAL 9016,

grey RAL 7047.

Housing: PA GF40.

Swivelling nut: Nickel-plated brass.

DN 65-125:

Cover: PBT, orange RAL 2011, grey

RAL 7043.

Bracket: Alu EN44200

Cables: Halogen free

AMETAL[®] is the dezincification resistant alloy of IMI Hydronic Engineering.

Surface treatment:

DN 15-50: Non treated

DN 65-125: Electrophoretic painting

Pipe connection:

DN 15-50: External thread according to ISO 228. Connections (accessories) with

internal thread NPT according to ANSI/ASME B1.20.1-1983, or for soldering

according to ASME/ANSI B16.18.

DN 65-125: Flanges according to ASME 7

ANSI B16.42 Class 150.

Certifications and directives:

EMC-D. 2014/30/EU: EN 60730-1, -2-14.

Product standards EN 60730-x.

PED: 2014/68/EU

Flow accuracy

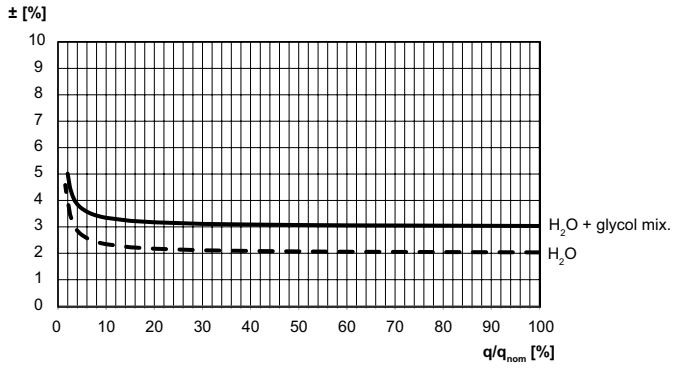

Installation

DN 15-50

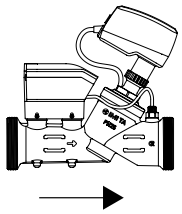

DN 65-125

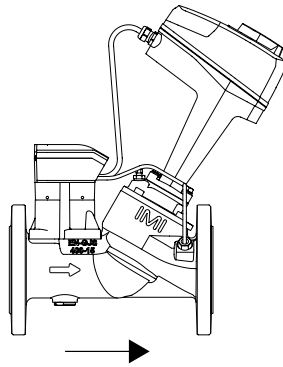

DN 15-50

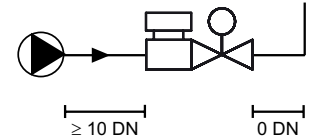
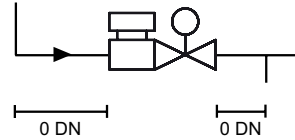

DN 65-125

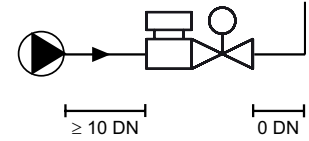
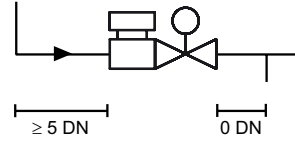

Note: Free space is required above the actuator/temperature sensor pocket for easy mounting/dismounting.

DN 15-50

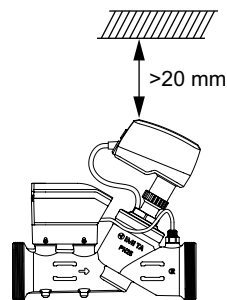

DN 65-125

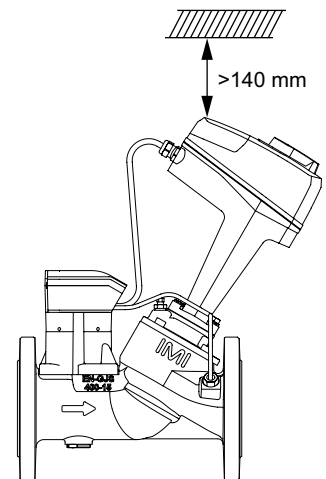

DN 15-50

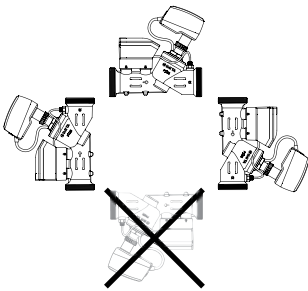

DN 65-125

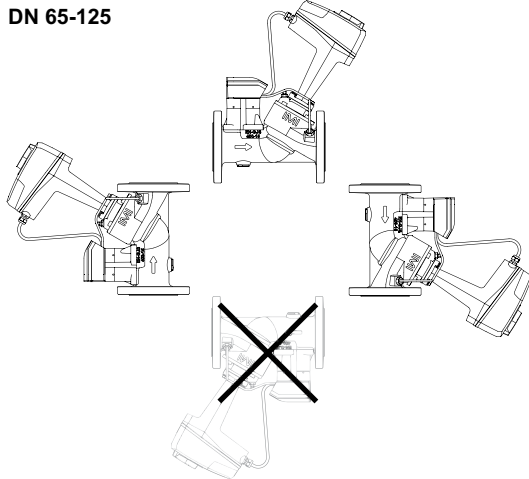

Articles

TA-Smart DN 15-50

Including temperature housing and 3 m temperature sensor cable.

(10 m cable on request, please contact IMI Hydronic Engineering)

External threads according to ISO 228.

NPT threads - see "Connections".

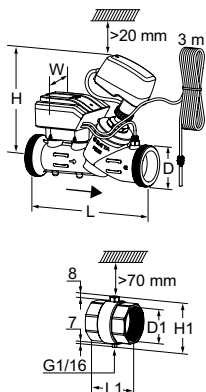

DN	(size)	D	L	H	W	Kvs	Kg	EAN	Article No
15	(1/2")	G3/4	167	173	97	1,90	1,4	7318794178243	322231-00115
20	(3/4")	G1	180	174	97	3,15	1,6	7318794174207	322231-00120
25	(1")	G1 1/4	187	174	97	4,35	1,8	7318794174306	322231-00125
32	(1 1/4")	G1 1/2	200	199	97	7,28	2,1	7318794164604	322231-00132
40	(1 1/2")	G2	218	198	97	12,3	3,0	7318794164703	322231-00140
50	(2")	G2 1/2	239	198	97	21,2	3,9	7318794164802	322231-00150

Temperature housing incl. temperature sensor pocket

Included in TA-Smart DN 15-50.

Internal thread NPT according to ANSI/ASME B1.20.1-1983.

DN	(size)	D1	L1	H1
15	(1/2")	1/2 NPT	52	55
20	(3/4")	3/4 NPT	55	56
25	(1")	1 NPT	64	61
32	(1 1/4")	1 1/4 NPT	66	71
40	(1 1/2")	1 1/2 NPT	67	77
50	(2")	2 NPT	68	89

TA-Smart DN 65-125

Including temperature sensor pocket and 5 m temperature sensor cable.

(10 m cable on request, please contact IMI Hydronic Engineering)

Free space >70 mm is required above the temperature pocket.

Flanges according to ASME 7 ANSI B16.42 Class 150.

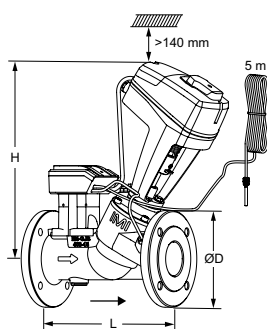

DN	(size)	Number of bolt holes	D	L	H	Kvs	Kg	EAN	Article No
Class 150									
65	(2 1/2")	4	180	290	377	49	16,5	7318794171008	322231-01465
80	(3")	4	190	310	380	73	18,6	7318794171107	322231-01480
100	(4")	8	229	350	438	120	29	7318794177901	322231-01490
125	(5")	8	254	400	444	190	35	7318794178007	322231-01491

→ = Flow direction

Kvs = m³/h at a pressure drop of 1 bar and fully open valve.

Accessories

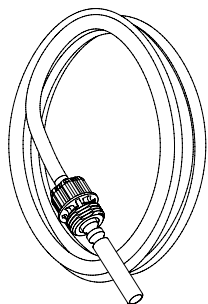

Temperature sensor

Included in TA-Smart/Fail-safe/-Dp.

(10 m cable on request, please contact IMI Hydronic Engineering)

Tool for exchanging temperature sensor is included.

For DN	Length [m]	EAN	Article No
15-25	3	7318794178229	322230-01106
32-50	3	7318794173705	322230-01100
65-125	5	7318794173804	322230-01101

DN 15-80 DN 100-125

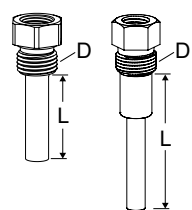

Temperature sensor pocket

Included in TA-Smart/Fail-safe/-Dp DN 65-125.

For mounting directly on pipe. Free space >70 mm is required above the temperature sensor pocket.

Valve DN	D	L	EAN	Article No
15-25	1/4 NPT	14	7318794174702	322230-00501
32-80	1/4 NPT	30	7318794174801	322230-00500
100-125	3/8 NPT	58	7318794178182	322230-00502

Temperature housing incl. temperature sensor pocket

Included in TA-Smart DN 15-50.

To be ordered separately if the pipe size does not match the valve size.

Internal thread NPT according to ANSI/ASME B1.20.1-1983.

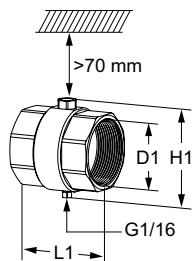

DN	(size)	D1	L1	H1	EAN	Article No
15	(1/2")	1/2 NPT	52	55	7318794178298	322230-00315
20	(3/4")	3/4 NPT	55	56	7318794175105	322230-00320
25	(1")	1 NPT	64	61	7318794175204	322230-00325
32	(1 1/4")	1 1/4 NPT	66	71	7318794171701	322230-00332
40	(1 1/2")	1 1/2 NPT	67	77	7318794171800	322230-00340
50	(2")	2 NPT	68	89	7318794171909	322230-00350

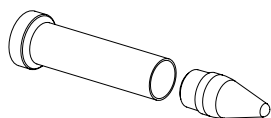

Service tool

	EAN	Article No
For exchange of temperature sensor	7318794178144	322033-00000
For exchange of TA-Slider cable	7318794178151	322033-00001

Insulation

For heating and non-condensing cooling applications.

Material: EPP.

Fire class: E (EN 13501-1), B2 (DIN 4102).

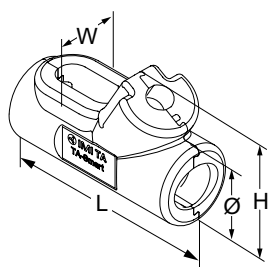

For DN	L	H	W	Ø	EAN	Article No
15	-	-	-	-	-	-
20	215	112	76	69	5902276819681	322230-00620
25	225	119	86	82	5902276819698	322230-00625
32	238	153	92	96	5902276819438	322230-00632
40	256	168	110	114	5902276819360	322230-00640
50	284	183	134	143	5902276819377	322230-00650

Connections

With internal thread NPT

Threads according to ANSI/ASME B1.20.1-1983.

Swivelling nut

Brass/AMETAL®

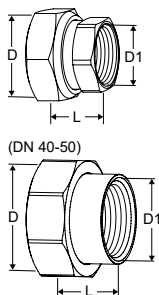

Valve DN	D	D1	L*	EAN	Article No
15	G3/4	1/2 NPT	25	7318794017900	52 163-215
20	G1	1/2 NPT	18	7318794018303	52 163-320
20	G1	3/4 NPT	23	7318794018006	52 163-220
25	G1 1/4	3/4 NPT	27	7318794018402	52 163-325
25	G1 1/4	1 NPT	27	7318794018105	52 163-225
32	G1 1/2	1 NPT	27	7318794018501	52 163-332
32	G1 1/2	1 1/4 NPT	31	7318794018204	52 163-232
40	G2	1 NPT	30	7318794033108	52 163-340
40	G2	1 1/2 NPT	32	7318794032903	52 163-240
50	G2 1/2	1 1/2 NPT	32	7318794033207	52 163-350
50	G2 1/2	2 NPT	32	7318794033009	52 163-250

Soldering connection

According to ASME/ANSI B16.18

Swivelling nut

Brass/gunmetal CC491K (EN 1982)

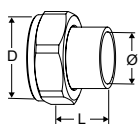

Valve DN	D	Pipe Ø [in]	~ [mm]	L*	EAN	Article No
15	G3/4	0.629	16	16	7318794022904	52 009-715
20	G1	0.879	22	22	7318794023000	52 009-720
25	G1 1/4	1.130	29	26	7318794023109	52 009-725
32	G1 1/2	1.380	35	28	7318794023208	52 009-732
40	G2	1.630	41	31	7318794033900	52 009-740
50	G2 1/2	2.130	54	38	7318794034006	52 009-750

*) Fitting length (from the gasket surface to the end of the connection).

Other type of connections (ISO), see international version of TA-Smart.

