

TA-Slider 1600 Fail-safe Plus



Actuators

Digitally configurable proportional push-pull actuator with electronic fail-safe function – 1600 N

TA-Slider 1600 Fail-safe Plus

Digitally configurable fail-safe actuators for all control systems with or without change-over. Wide range of setup possibilities gives high flexibility to adapt parameters on-site. Fully programmable binary input, relay and adjustable max. stroke of the valve bring new opportunities for advanced hydronic control and balancing.



Key features

- > **Fully configurable fail-safe**
Setting of stroke position (extended, retracted or intermediate position) and delay feature for entering/leaving fail-safe mode for a reliable and optimal fail-safe function.
- > **Fully configurable**
More than 200 setup options allow input and output signals, binary input, relay, characteristics and many other parameters to be configured.
- > **Convenient, reliable setup**
Fully customisable by smartphone via Bluetooth using a TA-Dongle.
- > **Easy diagnostics**
Tracks the last 10 errors to allow system faults to be found quickly and health check of fail-safe function.

Technical description

Functions:

Electronic fail-safe function
Proportional control
3-point control
On-off control
Manual override
Stroke detection
Mode, status and position indication
Output signal VDC
Stroke limitation setting
Minimum stroke setting
Valve blockage protection
Valve clogging detection
Error safe position
Diagnostic/Logging
Delayed start-up

With relay board

- + 1 binary input, max. 100 Ω , cable max. 10 m or shielded.
- + 2 relays, max. 3A, 30 VDC/250 VAC on resistive load
- + Output signal in mA

Fail-safe function:

Programmable actuator's stem extended, retracted or intermediate position on power failure.

Supply voltage:

24 VAC/VDC $\pm 15\%$.
100-240 VAC $\pm 10\%$.
Frequency 50/60 Hz ± 3 Hz.

Power consumption:

24 VAC/VDC:
Peak: < 21.7 VA (VAC); < 8.7 W (VDC)
Operation: < 12.0 VA (VAC); < 6.0 W (VDC)
Standby: < 1.8 VA (VAC); < 0.7 W (VDC)
100-240 VAC:
Peak: < 20.8 VA (VAC)
Operation: < 15.6 VA (VAC)
Standby: < 4.3 VA (VAC)
Peak consumption occurs for a short period after a power cut for recharging capacitors.

Input signal:

0(2)-10 VDC, R_i 47 k Ω .
Adjustable sensitivity 0.1-0.5 VDC.
0.33 Hz low pass filter.
0(4)-20 mA R_i 500 Ω .
Proportional:
0-10, 10-0, 2-10 or 10-2 VDC
0-20, 20-0, 4-20 or 20-4 mA

Proportional split-range:

0-5, 5-0, 5-10 or 10-5 VDC
0-4.5, 4.5-0, 5.5-10 or 10-5.5 VDC
2-6, 6-2, 6-10 or 10-6 VDC
0-10, 10-0, 10-20 or 20-10 mA
4-12, 12-4, 12-20 or 20-12 mA

Proportional dual-range (for change-over):

0-3.3 / 6.7-10 VDC,
10-6.7 / 3.3-0 VDC,
2-4.7 / 7.3-10 VDC or
10-7.3 / 4.7-2 VDC.
Default setting: Proportional 0-10 VDC.

Output signal:

0(2)-10 VDC, max. 8 mA, min. 1.25 k Ω .
0(4)-20 mA, max. 700 Ω .
Ranges: See "Input signal".
Default setting: Proportional 0-10 VDC.

Characteristics:

Linear, EQM 0.25 and inverted EQM 0.25.
Default setting: Linear.

Control speed:

3, 4, 6, 8, 12 or 16 s/mm
Default setting: 3 s/mm

Fail-safe delay:

Adjustable between 0 and 10 seconds.
Default setting: 2 s

Power supply stabilisation delay:

Adjustable between 1 and 5 seconds.
Default setting: 2 s

Pre-charging time:

< 70 s

Adjusting force:

1600 N

Temperature:

Media temperature: 0°C – +120°C
Operating environment: 0°C – +50°C
(5-95%RH, non-condensing)
Storage environment: -20°C – +50°C
(5-95%RH, non-condensing)

Ingress protection:

IP54 (all directions)
(according to EN 60529)

Protection class:

(according to EN 61140)
100-240 VAC: Class I
24 VAC/VDC: Class I

Stroke:

Max. 33 mm
Automatic detection of the valve lift
(stroke detection).

Noise level:

Max. 40 dBA

Weight:

1,6 kg

Connection to valve:

By two M8 screws to the valve and by
quick connection to the stem.

Material:

Cover: PBT
Bracket: Alu EN44200

Colour:

Orange RAL 2011, grey RAL 7043.

Marking:

IMI TA, product name, article No. and
technical specification.
LED indication description.

Certification CE:

LV-D. 2014/35/EU: EN 60730-1, -2-14.
EMC-D. 2014/30/EU: EN 60730-1, -2-14.
RoHS-D. 2011/65/EU: EN 63000.

Product standard:

EN 60730.
(for Residential and industrial areas)

Cable:

Wire cross-section*: 0.5-2.0 mm²
Protection class I: H05VV-F or similar
Protection class III: LiYY or similar

*) **Note:** Wire cross-sections must be
chosen according to actuator power
consumption and line length, such as the
voltage supply to the actuator does not
go below 20.4 VAC/VDC (24 VAC/VDC
minus 15%).
In case of VDC input signal on a 24 VAC/
VDC powered actuator, the voltage drop
on neutral line must be smaller than the
defined hysteresis level for the VDC input
signal.

Function

Setting

The actuator can be set by the HyTune app (iOS version 8 or later on iPhone 4S or later, Android version 4.3 or later) + the TA-Dongle device, with or without the actuator power supplied. The setting configuration can be stored in the TA-Dongle for setting of one or several actuators. Connect the TA-Dongle to the actuator and press the configuration button. HyTune can be downloaded from the App Store or Google Play.

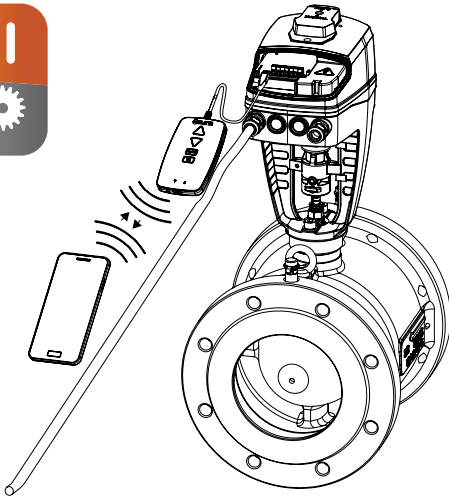

Manual override

By 5 mm Allen key or by the TA-Dongle device.

Note: Power supply needed when TA-Dongle is used.

Position indicator

Visible mechanical stroke indication on the bracket.

Calibration/Stroke detection

According to selected settings in the table.

Type of calibration	At power on	After manual override
Both end positions (full)	√ *	√
Fully extended position (fast)	√	√ *
None	√	

*) Default

Note: A calibration refresh can be automatically repeated monthly or weekly.

Default setting: Off.

Stroke limitation setting

A maximum stroke smaller than or equal to the detected valve lift can be set to the actuator.

For some TA/HEIMEIER valves it can also be set to a Kv_{max}/q_{max} .
Default setting: No stroke limitation (100%).

Minimum stroke setting

The actuator can be set with a minimum stroke below which it will not go (except for calibration).

For some TA/HEIMEIER valves, it can also be set to a q_{min} .
Default setting: No minimum stroke (0%).

Valve blockage protection

The actuator will perform a quarter of a full stroke and then back to desired value if no actuation takes place for one week or one month.

Default setting: Off.

Valve clogging detection

If actuation stops before the desired value is reached, the actuator moves back ready to make a new attempt. The actuator will move to the configured error safe position after three attempts.

Default setting: On.

Error safe position

Fully extended or retracted position when following errors occur; low power, line break, valve clogging or stroke detection failure.

Default setting: Fully extended position.

Diagnostics/logging

The last 10 errors (low power, line break, valve clogging, stroke detection failure) with time stamps can be read using the HyTune app + TA-Dongle device. Logged errors will be cleared if the power is disconnected.

Delayed start-up

The actuator can be specified a delay (0 to 1275 sec.) before starting up after a power supply cut. This is useful when used with a control system that has itself a long start-up time.

Default setting: 0 seconds.

Fail-safe

Goes to a pre-defined position when power supply is lost.

Pre-defined position settable to any position and delay before entering fail-safe mode after a power off settable between 0 and 10 seconds.

Default setting: Fully retracted and 2 seconds delay.

Going back to normal operation when power is back for more than a power supply stabilization delay settable between 1 and 5 seconds.

Default setting: 2 seconds.

Capacitor charge/health level of the fail-safe function is indicated by the colour of the fail-safe LED. A complete health check of the fail-safe function can be launched with the HyTune app.

Binary input

If the binary input circuit is open, the actuator will go to a set stroke, switch to a second stroke limitation setting or drive to its full stroke regardless of any limitations for flushing purpose. See also Change-over system detection.

Default setting: Off

Change-over system detection

Switching between two different stroke limitation settings by toggling the binary input or using the dual-range input signal.

LED indication

		Status	Green
		Fully retracted (actuator stem)	Long pulse - Short pulse
		Fully extended (actuator stem)	Short pulse - Long pulse
		Intermediate position	Long pulses
		Moving	Short pulses
		Calibrating	2 short pulses
		Manual mode or no power supply	Off

		Error code	Red
		Power supply too low	1 pulse
		Line broken (2-10 V or 4-20 mA)	2 pulses
		Valve clogging or foreign object	3 pulses
		Stroke detection failure	4 pulses

If an error is detected, red pulses are displayed as the green status lights flash alternately. More detailed information, please see the HyTune app + TA-Dongle.

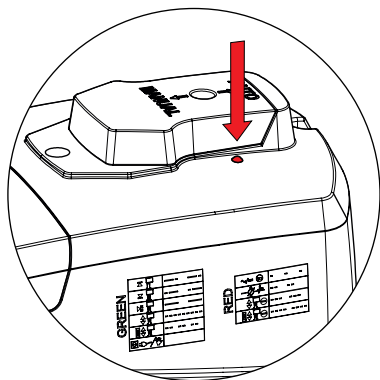

Installation

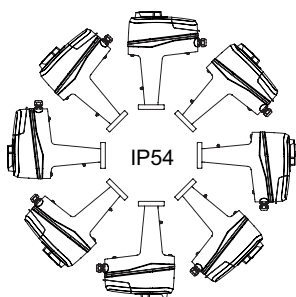

Note!

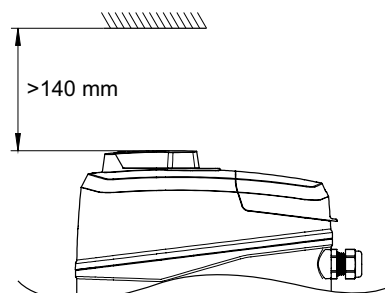

Connection diagram – Terminal/Description

Terminal	Description
L24	Power supply 24 VAC/VDC
M*	Neutral for power supply 24 VAC/VDC and signals
L	Power supply 100-240 VAC
N	Neutral for power supply 100-240 VAC
Y _i	Input signal for proportional control 0(4)-20 mA, 500 Ω
Y _v	Input signal for proportional control 0(2)-10 VDC, 47 kΩ
X _i	Output signal 0(4)-20 mA, max. resistance 700 Ω
X _v	Output signal 0(2)-10 VDC, max. 8 mA or min. load resistance 1.25 kΩ
Dw	3-point control signal for extending actuator spindle (24 VAC/VDC or 100-240 VAC)
Up	3-point control signal for retracting actuator spindle (24 VAC/VDC or 100-240 VAC)
B	Connection for potential free contact (e.g. open window detection), max. 100 Ω, max. 10 m cable or shielded
COM1, COM2	Common relay contacts, max. 250 VAC, max. 5A @ 250 VAC on resistive load, max. 5A @ 30 VDC on resistive load
NC1, NC2	Normally closed contacts for relays 1 and 2
NO1, NO2	Normally open contacts for relays 1 and 2

*) All M terminals are internally connected.

Connection diagram – 24 V

0(2)-10 VDC

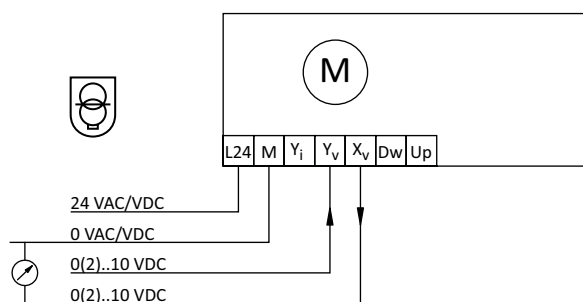

3-point

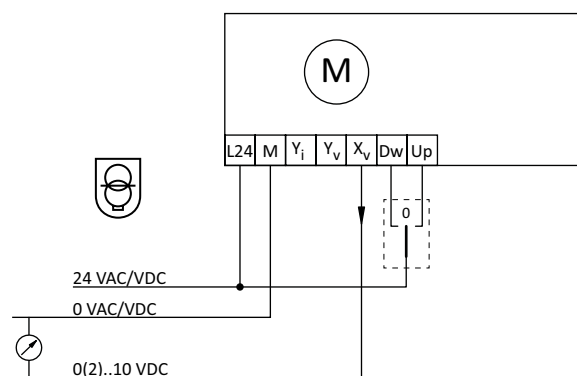

0(4)-20 mA

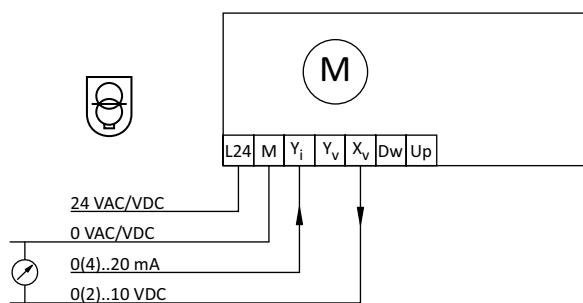

On-off

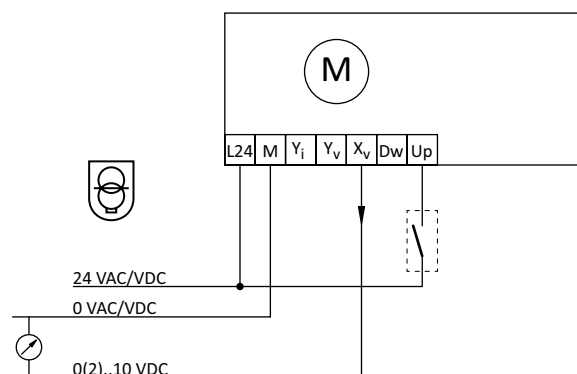

 24 VAC/VDC operating only with safety transformer according to EN 61558-2-6.

Connection diagram – 100-240 V

0(2)-10 VDC

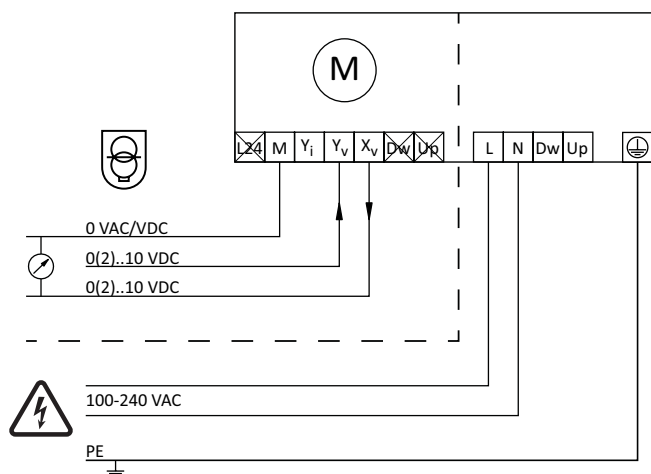

3-point

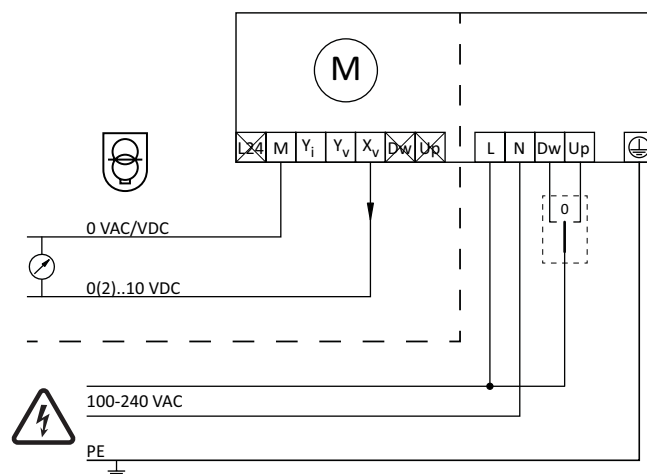

0(4)-20 mA

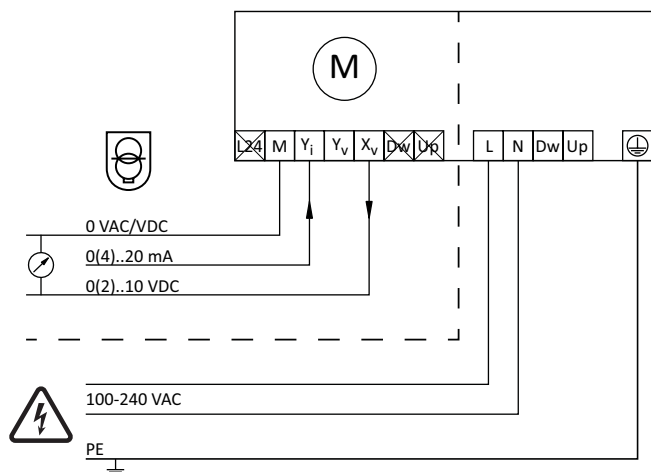

On-off

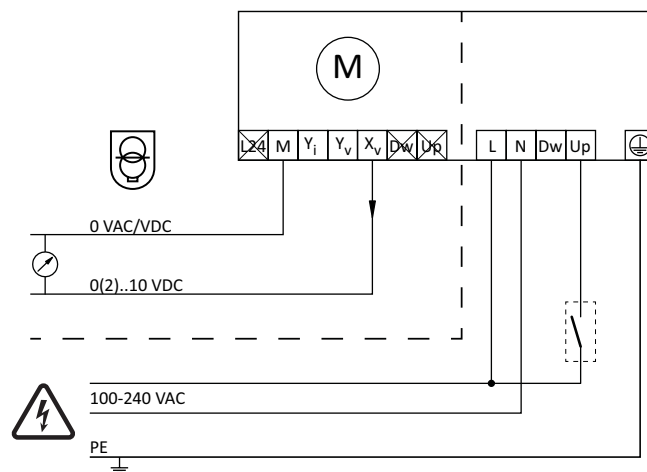

24 VAC/VDC operating only with safety transformer according to EN 61558-2-6.

Connection diagram – Relay

Optional relay board

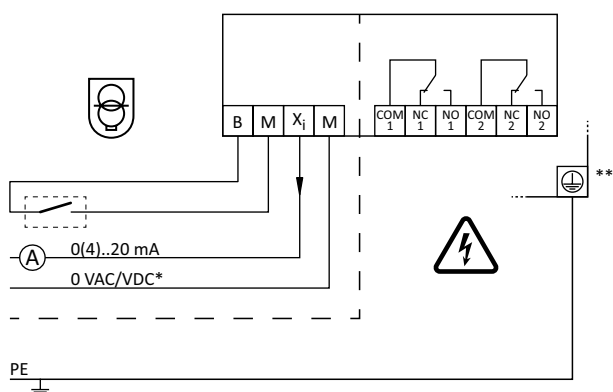

*) Low voltage neutral

**) Ground connection required.

Articles

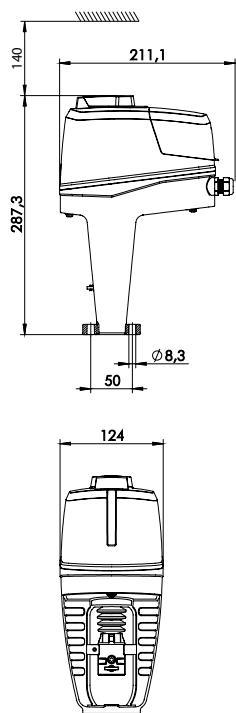

TA-Slider 1600 Fail-safe Plus

Input signal: 0(2)-10 VDC, 0(4)-20 mA, 3-point, on-off

With binary input, relays, mA output signal

Supply voltage	EAN	Article No
24 VAC/VDC	5902276816987	322228-10319
100-240 VAC	5902276816994	322228-40319

Additional equipment

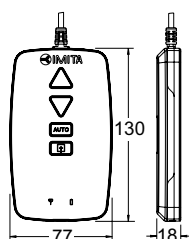

TA-Dongle

For Bluetooth communication with the HyTune app, transfer configuration settings and manual override.

EAN	Article No
5901688828632	322228-00001

Accessories

Stem heater

Including spindle top (extension) and extended screws.

Temperature range till $-10\text{ }^{\circ}\text{C}$.

Voltage $24\text{ VAC} \pm 10\%$ 50/60 Hz $\pm 5\%$.

Power P_N approx. 30 W.

Current 1,4 A.

Surface temperature max. $50\text{ }^{\circ}\text{C}$.

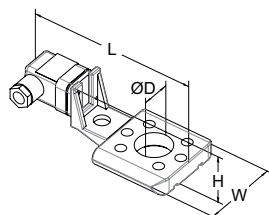

For valve	DN	L	H	W	D	EAN	Article No
KTM 512	65-125	146	49	70	30	3831112533455	322042-81401
TA-Modulator	65-200					3531112534834	322042-80010

The products, texts, photographs, graphics and diagrams in this document may be subject to alteration by IMI Hydronic Engineering without prior notice or reasons being given. For the most up to date information about our products and specifications, please visit www.imi-hydronic.com.