

# STAD-D



## Balancing valves

For domestic water systems, DN 10-50

# STAD-D

The STAD-D balancing valve delivers accurate hydronic performance in an impressive range of applications. Ideally suited for use in domestic water systems and on the secondary side in heating and cooling systems.

## Key features

- > **High accuracy for all settings**  
Ensure accurate balancing and flow reading.
- > **Handwheel**  
Equipped with a digital read-out, the handwheel ensures accurate and straightforward balancing. Positive shut-off function for easy maintenance.
- > **Self-sealing measuring points**  
For simple, accurate balancing.
- > **AMETAL®**  
Dezincification resistant alloy that guarantees a longer valve lifetime and lowers the risk of leakage.
- > **Special surface treatment**  
Ideal for high demanding domestic water applications.



## Technical description

### Application:

Domestic water systems  
Heating and cooling systems

### Functions:

Balancing  
Pre-setting  
Measuring  
Shut-off  
Draining

### Dimensions:

DN 10-50

### Pressure class:

PN 25

### Temperature:

Max. working temperature: 120°C.  
(For higher temperatures max. 150°C,  
please contact the nearest sales office).  
Min. working temperature: -20°C

### Media:

Water or neutral fluids, water-glycol  
mixtures (0-57%).

### Material:

Valve body and bonnet: AMETAL®  
Sealing (body/bonnet): EPDM O-ring  
Valve plug: AMETAL®  
Seat seal: EPDM O-ring  
Spindle: AMETAL®  
Slip washer: PTFE  
Spindle seal: EPDM O-ring  
Spring: Stainless steel  
Handwheel: Polyamide and TPE

Measuring points: AMETAL®  
Sealings: EPDM  
Caps: Polyamide and TPE

Draining: AMETAL®  
Sealing: EPDM  
Gaskets: Fiber-based aramid

AMETAL® is the dezincification resistant  
alloy of IMI Hydronic Engineering.

### Surface treatment:

Valve body, bonnet, valve plug are  
completely coated with T.E.A. (TERNARY  
ECO ALLOY) PLUS®.  
*T.E.A. is a registered trademark of La  
Tecnogalvano.*

### Marking:

Body: IMI, TA, PN 25/400 WWP, DN and  
inch size. DN 50 also CE.  
Handwheel: TA, STAD-D\* and DN.

### Connection:

Female thread according to ISO 228.  
Thread length according to ISO 7/1.

### Approvals:

Approved for tap water systems (PN 25)  
by RISE (Research Institutes of Sweden).

## Measuring points

Measuring points are self-sealed. Remove the cap and insert the probe through the seal.

## Draining

Valves with draining for G3/4 hose connection.

## Sizing

When  $\Delta p$  and the design flow are known, use the formula to calculate the Kv value or use the diagram.

$$Kv = 0,01 \frac{q}{\sqrt{\Delta p}} \quad q \text{ l/h, } \Delta p \text{ kPa}$$

$$Kv = 36 \frac{q}{\sqrt{\Delta p}} \quad q \text{ l/s, } \Delta p \text{ kPa}$$

## Kv values

Turns	DN 10	DN 15	DN 20	DN 25	DN 32	DN 40	DN 50
0.5	-	0.136	0.533	0.599	1.19	1.89	2.62
1	0.091	0.226	0.781	1.03	2.09	3.40	4.10
1.5	0.134	0.347	1.22	2.13	3.36	4.74	6.76
2	0.264	0.618	1.95	3.64	5.22	6.25	11.4
2.5	0.461	0.931	2.71	5.26	7.77	9.16	15.8
3	0.799	1.46	3.71	6.65	9.82	12.8	21.5
3.5	1.22	2.07	4.51	7.79	11.9	16.2	27.0
4	1.36	2.56	5.39	8.59	14.2	19.3	32.3

**NOTE:** In softwares (HySelect, HyTools) and balancing instrument (TA-SCOPE) the STAD-D, PN 25 version, is named STAD-D\*.

## Measuring accuracy

The zero position is calibrated and must not be changed.

### Deviation of flow at different settings

The curve (Fig. 1) is valid for valves with normal pipe fittings (Fig. 2). Try also to avoid mounting taps and pumps, immediately before the valve.

The valve can be installed with the opposite flow direction. The specified flow details are also valid for this direction although tolerances can be greater (maximum 5% more).

**Fig. 1**

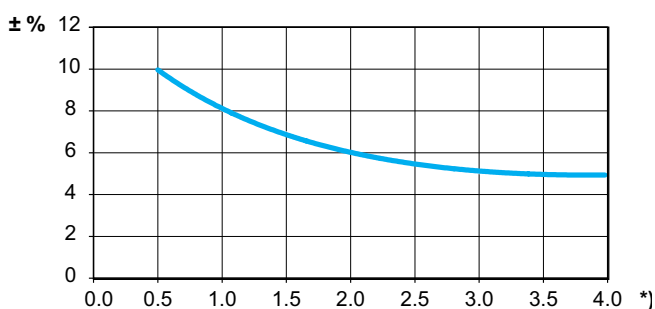

\*) Setting, No. of turns.

**Fig. 2**

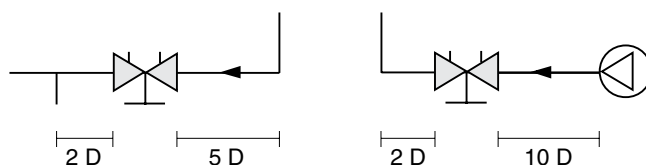

D = Valve DN

## Correction factors

The flow calculations are valid for water (+20°C). For other liquids with approximately the same viscosity as water ( $\leq 20$  cSt =  $3^\circ\text{E}=100\text{S.U.}$ ), it is only necessary to compensate for the specific density. However, at low temperatures, the viscosity increases and laminar flow may occur in the valves. This causes

a flow deviation that increases with small valves, low settings and low differential pressures. Correction for this deviation can be made with the software HySelect or directly in our balancing instruments.

## Setting

Setting of a valve for a particular pressure drop, e.g. corresponding to 2.3 turns on the graph, is carried out as follows:

1. Close the valve fully (Fig. 1).
2. Open the valve 2.3 turns (Fig. 2).
3. Using a 3 mm Allen key, turn the inner spindle clockwise until stop.
4. The valve is now set.

To check the setting: Close the valve, the indicator shows 0.0. Open it to the stop position. The indicator then shows the set value, in this case 2.3 (Fig. 2).

Diagrams showing the pressure drop for each valve size at different settings and flow rates are available to help determine the correct valve size and pre-setting (pressure drop).

Four turns corresponds to fully opened valve (Fig. 3). Opening it further will not increase the capacity.

**Fig. 1**  
Valve closed



**Fig. 2**  
The valve is set at 2.3



**Fig. 3**  
Fully open valve



## Diagram example

### Wanted:

Presetting for DN 25 at a desired flow rate of 1,6 m<sup>3</sup>/h and a pressure drop of 10 kPa.

### Solution:

Draw a straight line joining 1,6 m<sup>3</sup>/h and 10 kPa. This gives Kv=5,06. Now draw a horizontal line from Kv=5,06. This intersects the bar for DN 25 which gives 2,44 turns.

### NOTE:

If the flow rate is out of the scale in the diagram, the reading can be made as follows:

Starting with the example above, we get 10 kPa, Kv=5.06 and flow-rate 1.6 m<sup>3</sup>/h.

At 10 kPa and Kv=0.506 we get the flow-rate 0.16 m<sup>3</sup>/h, and at Kv=50.6, we get 16 m<sup>3</sup>/h. That is, for a given pressure drop, it is possible to read 10 times or 0.1 times the flow and Kv-values.

## Diagram

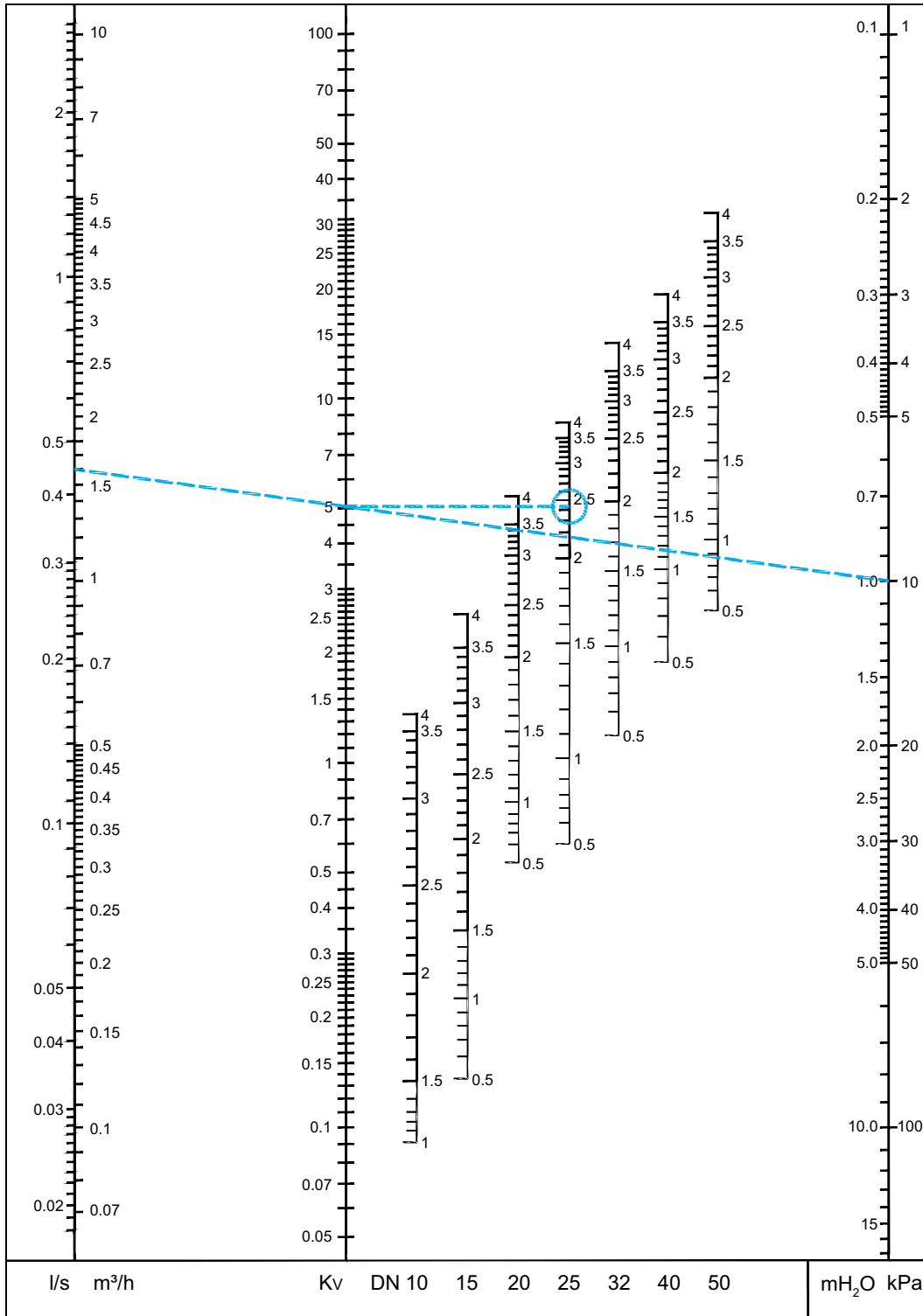

**NOTE:** In softwares (HySelect, HyTools) and balancing instrument (TA-SCOPE) the STAD-D, PN 25 version, is named STAD-D\*.

## Articles

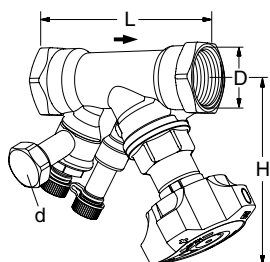

### With drain

Female threads.

Thread according to ISO 228. Thread length according to ISO 7/1.

DN	D	L	H	Kvs	Kg	EAN	Article No
<b>d = G3/4</b>							
10*	G3/8	73	100	1,36	0,53	5902276836114	52 752-610
15*	G1/2	84	100	2,56	0,56	5902276836121	52 752-615
20*	G3/4	94	100	5,39	0,64	5902276836138	52 752-620
25	G1	105	105	8,59	0,77	5902276836145	52 752-625
32	G1 1/4	121	110	14,2	1,1	5902276836152	52 752-632
40	G1 1/2	126	120	19,3	1,5	5902276836169	52 752-640
50	G2	155	120	32,3	2,1	5902276836176	52 752-650

→ = Flow direction

Kvs = m<sup>3</sup>/h at a pressure drop of 1 bar and fully open valve.

\*) Can be connected to smooth pipes by KOMBI compression coupling.

**NOTE:** In softwares (HySelect, HyTools) and balancing instrument (TA-SCOPE) the STAD-D, PN 25 version, is named STAD-D\*.

## Accessories

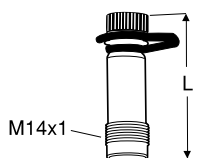

### Measuring point

Max 120°C (intermittent 150°C)

AMETAL®/EPDM

L	EAN	Article No
44	7318792813207	52 179-014
103	7318793858108	52 179-015

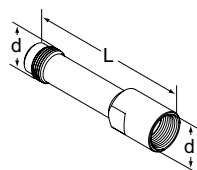

### Extension for measuring point M14x1

Suitable when insulation is used.

AMETAL®

d	L	EAN	Article No
M14x1	71	7318793969507	52 179-016

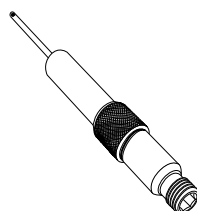

### Measuring point, extension 60 mm

(not for 52 179-000/-601)

Can be installed without draining of the system.

AMETAL®/Stainless steel/EPDM

L	EAN	Article No
60	7318792812804	52 179-006

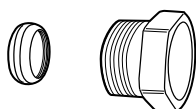

### KOMBI compression coupling

Max.: 100°C  
(For more information see catalogue leaflet KOMBI.)

Male pipe threads on thrust screw	For pipes, diameter	EAN	Article No
G3/8	10	7318792874604	53 235-104
G3/8	12	7318792874703	53 235-107
G1/2	10	7318792874901	53 235-109
G1/2	12	7318792875007	53 235-111
G1/2	14	7318792875106	53 235-112
G1/2	15	7318792875205	53 235-113
G1/2	16	7318792875304	53 235-114
G3/4	15	7318792875403	53 235-117
G3/4	18	7318792875601	53 235-121
G3/4	22	7318792875700	53 235-123

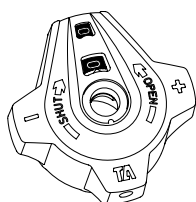

### Handwheel

Complete

EAN	Article No
7318794043503	52 186-007

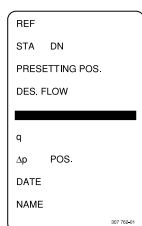

### Identification tag

EAN	Article No
7318792779206	52 161-990



### Allen key

[mm]		EAN	Article No
3	Pre-setting	7318792836008	52 187-103
5	Draining	7318792836107	52 187-105

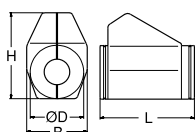

### Insulation

For heating/cooling  
CFC-free polyurethane. Covered with grey PVC.

See catalogue leaflet "Prefab insulations" for complete details.

For DN	L	H	D	B	EAN	Article No
10-20	155	135	90	103	7318792839108	52 189-615
25	175	142	94	103	7318792839306	52 189-625
32	195	156	106	103	7318792839504	52 189-632
40	214	169	108	113	7318792839702	52 189-640
50	245	178	108	114	7318792839900	52 189-650

