

Climate
Control

IMI TA

Raditrim



Return lockshields

With consistent presetting

Raditrim

The Raditrim is used in warm water pump heating systems and air conditioning systems. It makes possible the individual shut-off e.g. of radiators in order to carry out painting or maintenance work, without having to shut down other radiators. The presetting cone which is integrated into the shut-off cone makes a hydraulic balance possible through presetting.



Key features

Consistent presetting

Set the right flow level in advance for more accurate balancing. Simple allen key operation.

Double spindle

Separate spindles for presetting and shut-off ensures easier maintenance.

Technical description

Applications:

Heating and cooling systems.

Function:

Presetting
Shut-off

Dimensions:

DN 10-15

Pressure class:

PN 10 or PN 16

Temperature:

Max. working temperature: 120°C

Min. working temperature: -10°C

Materials:

Valve body: Brass

Spindles: Brass

O-rings: EPDM rubber

Radiator union: Brass

Surface treatment:

Valve body and fittings are nickel-plated.

Marking:

TA, DN

Standards:

Dimensions according to EN 215 series S.

Pipe connection:

The internal threaded version is designed for connection to threaded pipe, or in conjunction with compression fittings, to copper or precision steel pipe.

Not suitable for compression fitting for multi-layer pipes.

Construction

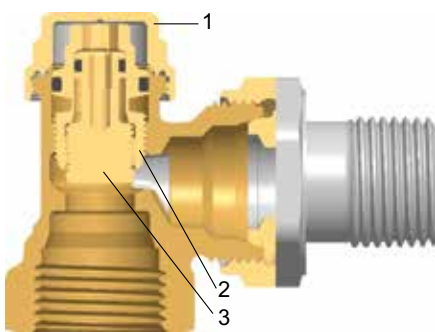

1. Closing cap
2. Shut-off cone
3. Presetting cone

Application

The Raditrim lockshield is used in warm water pump heating systems and air conditioning systems.

Versions DN 10 to DN 15, in angle and straight form make the threaded connection suitable for versatile and varied applications.

It makes possible the individual shut-off, e. g. of radiators in order to carry out painting or maintenance work, without having to shut down other radiators.

The presetting cone which is integrated into the shut-off cone makes a hydraulic balance possible through presetting.

The presetting is consistent, i. e. it is not changed when the shut-off is activated.

Sample application

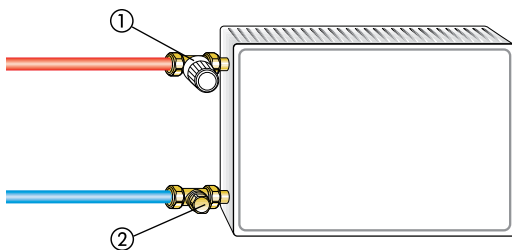

1. Thermostatic valve
2. Raditrim

Notes

To avoid damage and the formation of scale deposit in the hot-water heating system, the composition of the heat transfer medium should be in accordance with the VDI guideline 2035. For industrial and long-distance energy systems, see the applicable codes VdTÜV and 1466/AGFW FW 510. A heat transfer medium containing mineral oils, or any type of lubricant containing mineral oil can have extremely negative effects and usually lead to the disintegration of EPDM seals. When using nitrite-free frost and corrosion resistance solutions with an ethylene glycol base, pay close attention to the details outlined in the manufacturers' documentation, particularly concerning concentration and specific additives.

Operation

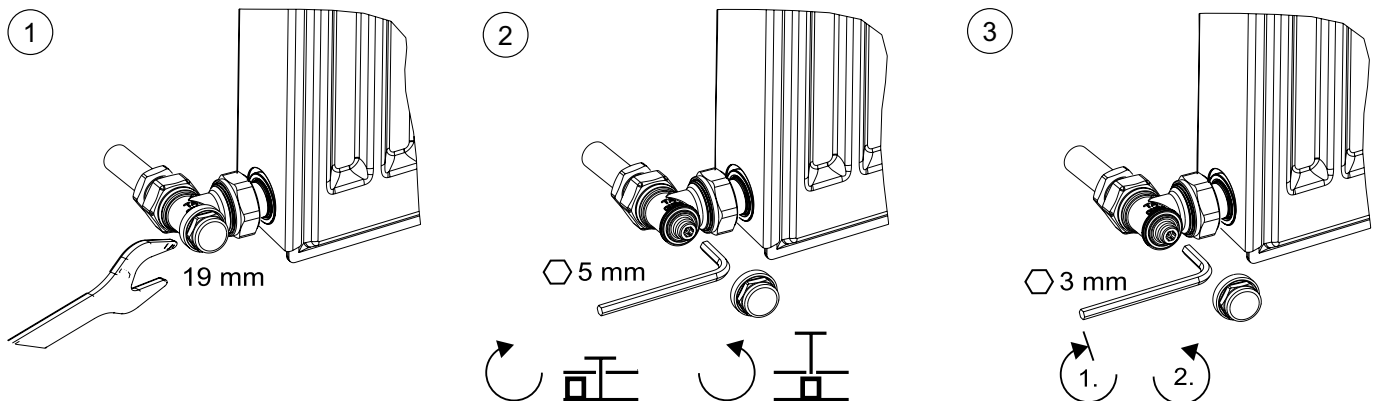

Presetting (PN 10 – 50 006/50 004)

Unscrew the closing cap with an open-jawed spanner SW 19 (fig. 1). Close the spindle by turning it to the right until it stops with a 5 mm allen key (fig. 2). Using a 3 mm allen key, screw in the presetting cone until it stops (smallest setting value 0). Set the required mass flow by turning the screw to the left (fig. 3). The setting value should be taken from the diagram. With a 5 mm allen key, open the spindle by turning it to the left until it stops. Unscrew the closing cap and tighten with an open-jawed spanner SW 19 (fig. 1).

The presetting is not changed when the radiator is shut-off.

Shut-off (PN 10 – 50 006/50 004)

Unscrew the closing cap using an open-jawed spanner SW 19 (fig. 1). Close the shut-off spindle by turning it to the right until it stops with a 5 mm allen key (fig. 2).

Presetting (PN 16 – 50 007)

Preset the valve by removing the cover and using a 3 mm allen key to close the presetting spindle (inner cone) completely. Open the presetting spindle by the number of turns as shown in the diagram to give the required setting. Check that the shut-off spindle (outer cone, allen key 4 mm) is fully open, and then finish by replacing the cover.

Note: If the valve is subsequently closed, the presetting will not be lost.

Shut-off (PN 16 – 50 007)

Unscrew the closing cap using an open-jawed spanner. Close the shut-off spindle (outer cone) by turning it to the right until it stops with a 4 mm allen key.

Technical data

Diagram DN 10 (3/8") – PN 10

Angle / Straight (50 006/50 004)

*) Revolution setting (Allen key 3 and 5 mm)

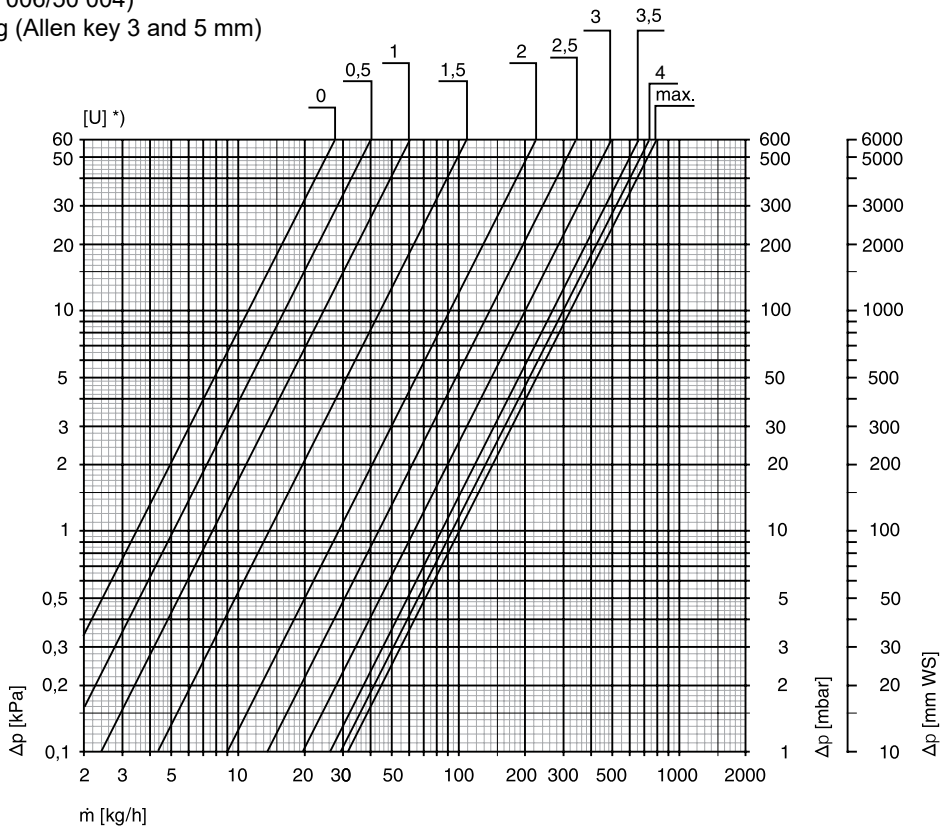

Diagram DN 15 (1/2") – PN 10

Angle / Straight (50 006/50 004)

*) Revolution setting (Allen key 3 and 5 mm)

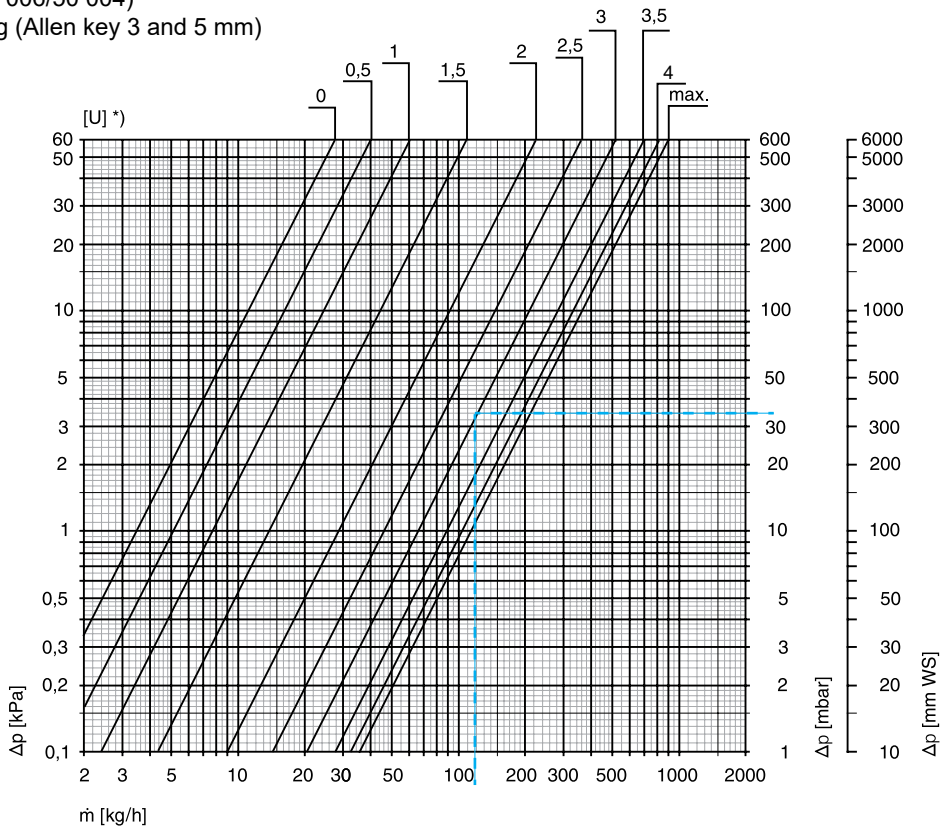

Diagram DN 10 (3/8") – PN 16

Straight (50 007)

*) Revolution setting (Allen key 3 and 4 mm)

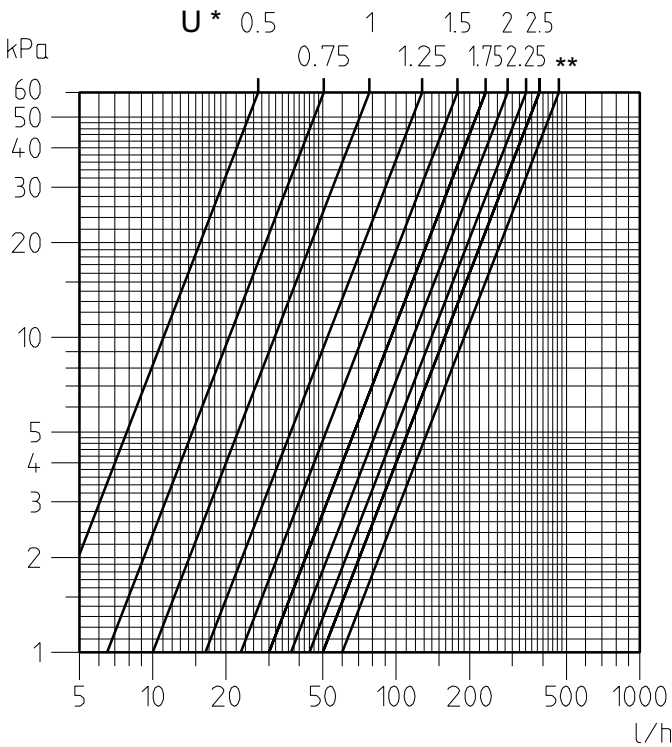
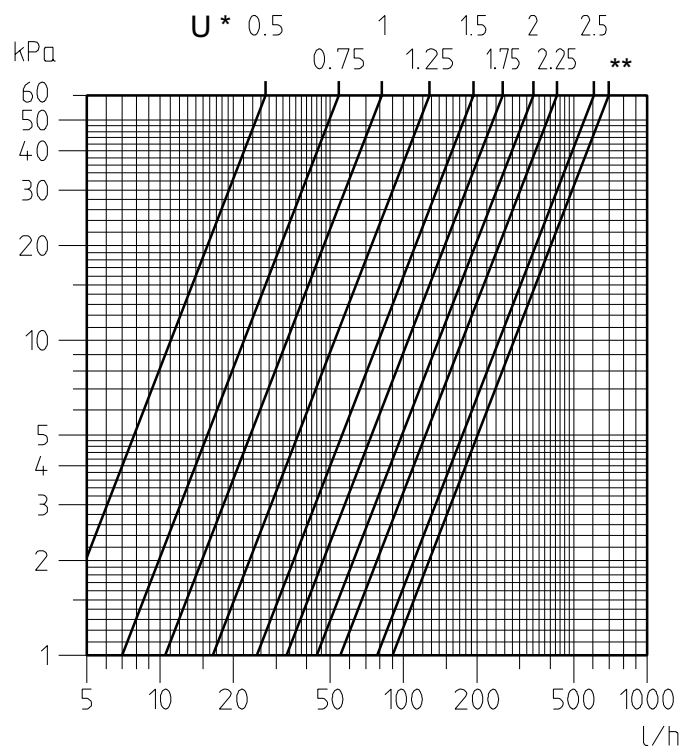

Diagram DN 15 (1/2") – PN 16

Straight (50 007)

*) Revolution setting (Allen key 3 and 4 mm)



DN	Kv-value									Kvs
	Revolution setting [U]									
PN 10	0	0,5	1	1,5	2	2,5	3	3,5	4	(4,25) max.
10 (3/8")	0,035	0,051	0,076	0,142	0,285	0,426	0,601	0,838	0,977	1,000
15 (1/2")	0,035	0,051	0,076	0,142	0,285	0,458	0,648	0,901	1,059	1,140
PN 16	0,5	0,75	1	1,25	1,5	1,75	2	2,25	2,5	(3) **
10 (3/8")	0,035	0,065	0,100	0,165	0,230	0,300	0,370	0,440	0,500	0,600
15 (1/2")	0,035	0,070	0,105	0,165	0,250	0,330	0,440	0,550	0,780	0,900

Delivery setting **) = Fully open

Calculation example

Required:

revolution setting DN 15

Given:

differential pressure to choke off $\Delta p = 3,4 \text{ kPa}$

heat flow $Q = 2095 \text{ W}$

temperature spread $\Delta t = 15 \text{ K (70/55}^\circ\text{C)}$

Solution:

mass flow $m = Q / (c \cdot \Delta t) = 2095 / (1,163 \cdot 15) = 120 \text{ kg/h}$

revolution setting = 3 (from diagram)

Articles

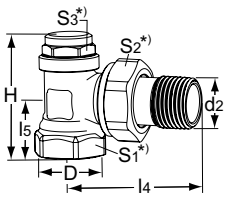

Angle
incl radiator union

DN	D	d2	l4	l5	H	Kvs	EAN	Article No
10	G3/8	R3/8	49	20	47	1,00	5901688829356	50 006-810
15	G1/2	R1/2	54	24	51	1,14	5901688829363	50 006-815

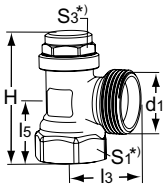

Angle
excl radiator union

DN	D	d1	l3	l5	H	Kvs	EAN	Article No
10	G3/8	M22x1,5	24	20	47	1,00	5901688829370	50 006-710
15	G1/2	M26x1,5	26	24	51	1,14	5901688829387	50 006-715

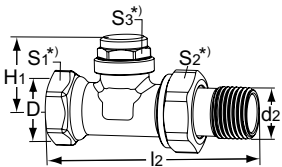

Straight
incl radiator union

DN	D	d2	l2	H1	Kvs	EAN	Article No
10	G3/8	R3/8	76	32	1,00	5901688829394	50 004-810
15	G1/2	R1/2	86	32	1,14	5901688829400	50 004-815

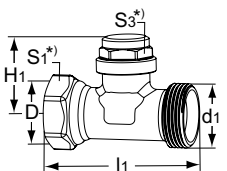

Straight
excl radiator union

DN	d2	d1	l1	H1	Kvs	EAN	Article No
10	G3/8	M22x1,5	50	32	1,00	5901688829417	50 004-710
15	G1/2	M26x1,5	58	32	1,14	5901688829424	50 004-715

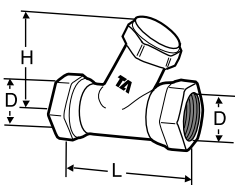

Straight – PN 16

Internal thread

Material: Valve body of AMETAL® and O-rings of Nitril. Cap marked with RADITRIM A

DN	D	L	H	Kvs	EAN	Article No
10	G3/8	52	33	0.6	7318792549304	50 007-610
15	G1/2	63	36	0.9	7318792549403	50 007-615

*)

S1: DN 10 = 22 mm, DN 15 = 27 mm

S2: DN 10 = 27 mm, DN 15 = 30 mm

S3: DN 10-15 = 19 mm

Kvs = m³/h at a pressure drop of 1 bar and fully open valve.

Raditrim can be connected to smooth pipes by means of the KOMBI compression coupling.
(See catalogue leaflet KOMBI).