

Compresso CX Connect



Pressure maintenance systems with external compressed air supply

For heating systems up to 4 MW and cooling systems up to 6 MW

Compresso CX Connect

The Compresso CX Connect is a precision pressurisation system with external supply of compressed air for heating, solar and chilled water systems. It is especially suitable in situations where compactness and accuracy are required. In terms of pressurisation capacity, the system lies between the Statico and Transfero ranges. The new **BrainCube Connect** control panel offers a new level of connectivity, enabling communication with the BMS system, other BrainCubes as well as remote operation of the pressurisation system through live viewing.



Technical description – Control unit TecBox

Applications:

Heating, solar and chilled water systems.
For systems according to EN 12828, SWKI HE301-01, solar systems according to EN 12976, ENV 12977 with on-site excess temperature protection in case of power outage.

Pressure:

Min. admissible pressure, PSmin: 0 bar
Max. admissible pressure, PS: see Articles

Ambient temperature:

Max. admissible ambient temperature, TA: 40°C
Min. admissible ambient temperature, TAmin: 5°C

Accuracy:

Precision pressure maintenance $\pm 0,1$ bar.

Supply voltage:

1 x 230V (-6% + 10%) / 50/60 Hz

Electric load:

See Articles.

Enclosure class:

IP according to EN 60529
IP 54

Material:

Main materials include steel, brass, and bronze.

Transportation and storage:

In frostless, dry places.

Standard:

Constructed according to
LV-D. 2014/35/EU
EMC-D. 2014/30/EU

Technical description – Expansion vessels

Applications:

Only together with Control unit TecBox.
See Applications under Technical description - Control unit TecBox.

Media:

Non-aggressive and non-toxic system media.
Addition of antifreeze agent up to 50%.

Pressure:

Min. admissible pressure, PSmin: 0 bar
Max. admissible pressure, PS: see Articles

Temperature:

Max. admissible bag temperature, TB: 70°C
Min. admissible bag temperature, TBmin: 5°C

For PED purposes:

Max. admissible temperature, TS: 120°C
Min. admissible temperature, TSmin: -10°C

Material:

Steel. Color beryllium.
Airproof butyl bag according to EN 13831.

Transportation and storage:

In frostless, dry places.

Standard:

Constructed according to PED 2014/68/EU.

Warranty:

Compresso CG, CG...E: 5-year warranty for the airproof butyl bag.
Compresso CU, CU...E: 5-year warranty for the vessel.

Function, Equipment, Features

Control unit BrainCube Connect

- BrainCube Connect control for an intelligent, fully automatic, safe system operation. Self-optimising with memory function.
- Resistive 3.5" TFT illuminated colour touch display. User-friendly, operation-orientated menu layout with slide and tap operation, step-by-step start up procedure guide and direct help in pop-up windows. Representation of all relevant parameters and operation status in plaintext and/or graphical, multilingual.
- Data logging and system analysis, chronological message memory with prioritisation, remote controllable with live view, periodical automatic selftest.
- Silent-run operation.
- Including assembly kit for the air-side connection of the TecBox with the primary vessel.
- High quality metal cover.
- Space-saving assembly on the CU or CG primary vessel.
- Fillsafe monitoring and control from an optional Pleno P water make-up unit .

Vessels

- Airproof butyl bag (CU, CU...E, CG, CG...E), exchangeable (CG, CG...E).
- Including flex tube for the water-side connection and lock shield valve with ball valve for fast draining (CU, CG).
- Including assembly kit for the air-side connection of the vessels and lock shield valve for the water-side connection with ball valve for fast draining (CU...E, CG...E).
- Corrosion-protected internal coating for minimum bag wear (CG, CG...E).
- Endoscopic inspection opening for internal inspections (CU, CU...E). Two flange openings for internal inspections (CG, CG...E).
- Bag can be vented at the top, condensate drain at the bottom.
- Sinus ring for upright installation.

Calculation

Pressure maintenance for systems TAZ ≤ 100°C

Calculation following EN 12828, SWKI HE301-01.

For all special applications such as solar systems, district heating systems, systems with temperatures above 100°C or cooling systems with temperatures below 5°C please use HySelect software or contact us.

General equations

Vs	Water capacity of the system		Vs = vs · Q	vs Q	Specific water capacity, table 4. Installed heat capacity
			Vs= Known		System design, content calculation
		Cooling	Vs= Known		System design, content calculation
Ve	Expansion volume	EN 12828	Ve=e · (Vs + Vhs)	e, ehs	Expansion coefficient for $t_{s_{max}}$, table 1
		Cooling	Ve=e · (Vs + Vhs)	e, ehs	Expansion coefficient for $t_{s_{max}}$, table 1 ⁷⁾
		SWKI HE301-01 heating	Ve=e · Vs · X¹⁾ + ehs · Vhs	e ehs	Expansion coefficient for $(t_{s_{max}} + t_r) / 2$, table 1 Expansion coefficient for $t_{s_{max}}$, table 1
		SWKI HE301-01 cooling	Ve=e · Vs · X¹⁾ + ehs·Vhs	e, ehs	Expansion coefficient for $t_{s_{max}}$, table 1 ⁷⁾
Vwr	Water reserve	EN 12828, Cooling	Vwr ≥ 0,005 · Vs ≥ 3 L		
		SWKI HE301-01	Vwr is considered in Ve with the coefficient X		
p0	Minimum pressure ²⁾ Lower limit value for the pressure maintenance	EN 12828, Cooling	p0 = Hst/10 + 0,2 bar ≥ pz	Hst	Static height
		SWKI HE301-01	p0=Hst/10 +0.3 bar ≥ pz	pz	Minimum required equipment pressure for pumps or boilers
pa	Initial pressure Lower threshold for an optimum pressure maintenance		pa ≥ p0 + 0,3 bar		
pe	Final pressure Upper threshold for an optimum pressure maintenance.			psvs dpsvs _c	Response pressure safety valve system Closing pressure tolerance of the safety valve
		EN 12828	pe ≤ psvs - dpsvs_c	dpsvs _c dpsvs _c	= 0,5 bar for psvs ≤ 5 bar ⁴⁾ = 0,1 · psvs for psvs > 5 bar ⁴⁾
		cooling	pe ≤ psvs - dpsvs_c	dpsvs _c dpsvs _c	= 0,6 bar for psvs ≤ 3 bar ⁴⁾ = 0,2 · psvs for psvs > 3 bar ⁴⁾
		SWKI HE301-01 heating	pe ≤ psvs/1.3 pe ≤ psvs/1.15		for psvs ≤ 3 bar ⁴⁾ for psvs > 3 bar ⁴⁾
		SWKI HE301-01 cooling	pe ≤ psvs/1.3 and pe ≤ psvs - 0.6 bar		psvs ⁴⁾

Compresso

pe	Final pressure		pe=pa+0,2		
VN	Nominal volume of the expansion vessel ⁵⁾	EN 12828, Cooling	VN ≥ (Ve + Vwr + 2³⁾ · 1,1		
		SWKI HE301-01	VN ≥ (Ve + 2³⁾ · 1,1		

1) Heating, Cooling, Solar: Q ≤ 10 kW: X = 3 | 10 kW < Q ≤ 150 kW: X = (87-0,3 · Q)/28 | Q > 150 kW: X = 1,5

Geothermal probe systems: X = 2,5

2) The formula for minimum pressure p0 applies to the installation of pressure maintenance on the suction side of the circulation pump. In case of a pressure-side installation p0 is to be increased by the pump pressure Δp.

3) Add 2 litres when a Vento is installed in the system.

4) The safety valves must operate within these limits. Use component tested and certified safety valves of type H and DGH for heating systems, type F for cooling systems.

5) Please select a vessel with an equal or higher nominal volume.

7) Max. system standstill temperature, usually 40°C for cooling applications and geothermal probes with ground regeneration, 20°C for other geothermal probes

*) SWKI HE301-01: Valid for Switzerland

HySelect calculation software is based on an advanced calculation method and database. Results may vary

Table 1: e expansion coefficient

t (TAZ, ts_{max}, tr, ts_{min}), °C	20	30	40	50	60	70	80	90	100	105	110
e Water = 0 °C	0,0016	0,0041	0,0077	0,0119	0,0169	0,0226	0,0288	0,0357	0,0433	0,0472	0,0513
e % weight MEG*											
30 % = -14,5 °C	0,0093	0,0129	0,0169	0,0224	0,0286	0,0352	0,0422	0,0497	0,0577	0,0620	0,0663
40 % = -23,9 °C	0,0144	0,0189	0,0240	0,0300	0,0363	0,0432	0,0505	0,0582	0,0663	0,0706	0,0750
50 % = -35,6 °C	0,0198	0,0251	0,0307	0,0370	0,0437	0,0507	0,0581	0,0660	0,0742	0,0786	0,0830
e % weight MPG**											
30 % = -12,9 °C	0,0151	0,0207	0,0267	0,0333	0,0401	0,0476	0,0554	0,0639	0,0727	0,0774	0,0823
40 % = -20,9 °C	0,0211	0,0272	0,0338	0,0408	0,0481	0,0561	0,0644	0,0731	0,0826	0,0873	0,0924
50 % = -33,2 °C	0,0288	0,0355	0,0425	0,0500	0,0577	0,0660	0,0747	0,0839	0,0935	0,0985	0,1036

Table 4: vs approx. water capacity * of central heating referred to the installed heat capacity Q**

ts_{max} tr	°C	90 70	80 60	70 55	70 50	60 40	50 40	40 30	35 28
Radiators	vs liter/kW	14,0	16,5	20,1	20,6	27,9	36,6	-	-
Flat radiators	vs liter/kW	9,0	10,1	12,1	11,9	15,1	20,1	-	-
Convectors	vs liter/kW	6,5	7,0	8,4	7,9	9,6	13,4	-	-
Air handlers	vs liter/kW	5,8	6,1	7,2	6,6	7,6	10,8	-	-
Floor heating	vs liter/kW	10,3	11,4	13,3	13,1	15,8	20,3	29,1	37,8

*) MEG = Mono-Ethylene Glycol

**) MPG = Mono-Propylene Glycol

***) Water capacity = heat generator + distribution net + heat emitters

Temperatures

ts_{max}	Maximum system temperature Maximum temperature for the calculation of the volume expansion. For heating systems the dimensioned flow temperature at which a heating system is to be operated with the lowest outside temperature to be assumed (standard outside temperature according to EN 12828). For cooling systems the max. temperature that is achieved due to the operation mode or standstill, for solar systems the temperature up to which an evaporation is to be avoided.
ts_{min}	Lowest system temperature Lowest temperature for calculating expansion volumes. The lowest system temperature is equal to the freezing point. It is dependant on the percentage of antifreeze additives. For water without additives ts _{min} = 0.
tr	Return temperature Return temperature of the heating system with the lowest outside temperature to be assumed (standard outside temperature according to EN 12828).
TAZ	Safety temperature limiter Safety temperature controller Temperature limit Safety device according to EN 12828 for the temperature protection of heat generators. If the set temperature limit is exceeded the heating is turned off. Limiters are locked, controllers automatically release the heat supply if the set temperature falls short. Setting value for systems according to EN 12828 ≤ 110 °C.

Precision pressure maintenance

The air controlled Compresso minimises pressure variations between p_a and p_e .
 $\pm 0,1$ bar

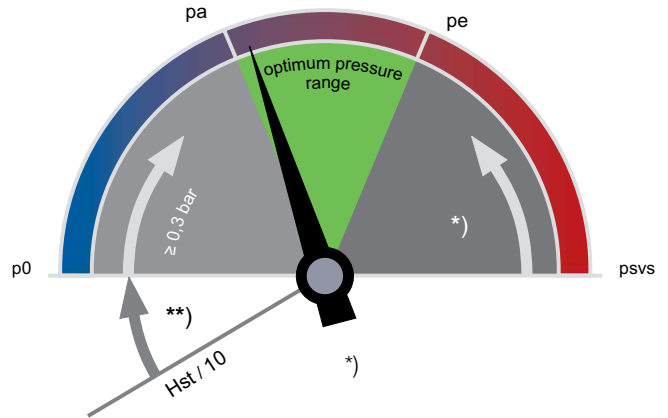

**)
 EN 12828, Solar, Cooling: $\geq 0,2$ bar
 SWKI HE301-01: $\geq 0,3$ bar

*)
 EN 12828: $\geq psvs \cdot 0,9 \geq 0,5$ bar
 Solar, Cooling: $\geq psvs \cdot 0,8 \geq 0,6$ bar
 SWKI HE301-01 Heating, $psvs \leq 3$ bar: $\geq psvs / 1,3$
 SWKI HE301-01 Heating, $psvs > 3$ bar: $\geq psvs / 1,15$
 SWKI HE301-01 Cooling: $\geq psvs / 1,3$

p0 Minimum pressure

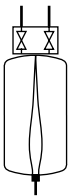

Compresso

p_0 and the switching points are calculated by the BrainCube.

pa Initial pressure

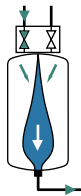

Compresso

If the system pressure is $< p_a$, the supply valve opens.
 $p_a = p_0 + 0,3$

pe Final pressure



Compresso

If system pressure is $> p_e$ the air relief valve opens.
 $p_e = p_a + 0,2$

Table 5: DNe standard values for expansion pipes with Compresso

Length up to approx. 30 m	DNe	20	25	32	40	50	65	80
Heating:								
EN 12828	Q kW	1000	1700	3000	3900	6000	11000	15000
SWKI HE301-01 *)	Q kW	300	600	900	1400	3000	6000	9000
Cooling:								
$ts_{max} \leq 50$ °C	Q kW	1600	2700	4800	6300	9600	17600	24100

*) Valid for Switzerland

Equipment

Expansion pipes

According to table 5. With multiple vessels to be calculated depending on the output per vessel.

Lock shield valve DLV

Included with delivery.

Zeparo

Air vent Zeparo ZUT or ZUP at each high point for venting while filling and/or draining. Separator for dirt and magnetite in each system in the main return to the heat generator. If no central degassing (Vento V Connect) is installed a microbubble separator can be added in the main flow, before the circulation pump where possible.

The static height (H_{st_m} per the following table) above the microbubble separators must not be exceeded.

$t_{s_{max}}$ °C	90	80	70	60	50	40	30	20	10
H_{st_m} mWs	15,0	13,4	11,7	10,0	8,4	6,7	5,0	3,3	1,7

Application examples

Compresso CX 80 Connect

TecBox with 1 air inlet and 1 air exit valve, wall-mounted besides the primary vessel, precision pressure maintenance ± 0.1 bar, with Pleno P BA4R and Pleno PX water make-up.

For heating systems up to approx. 4000 kW

(May require changes to meet local legislation)

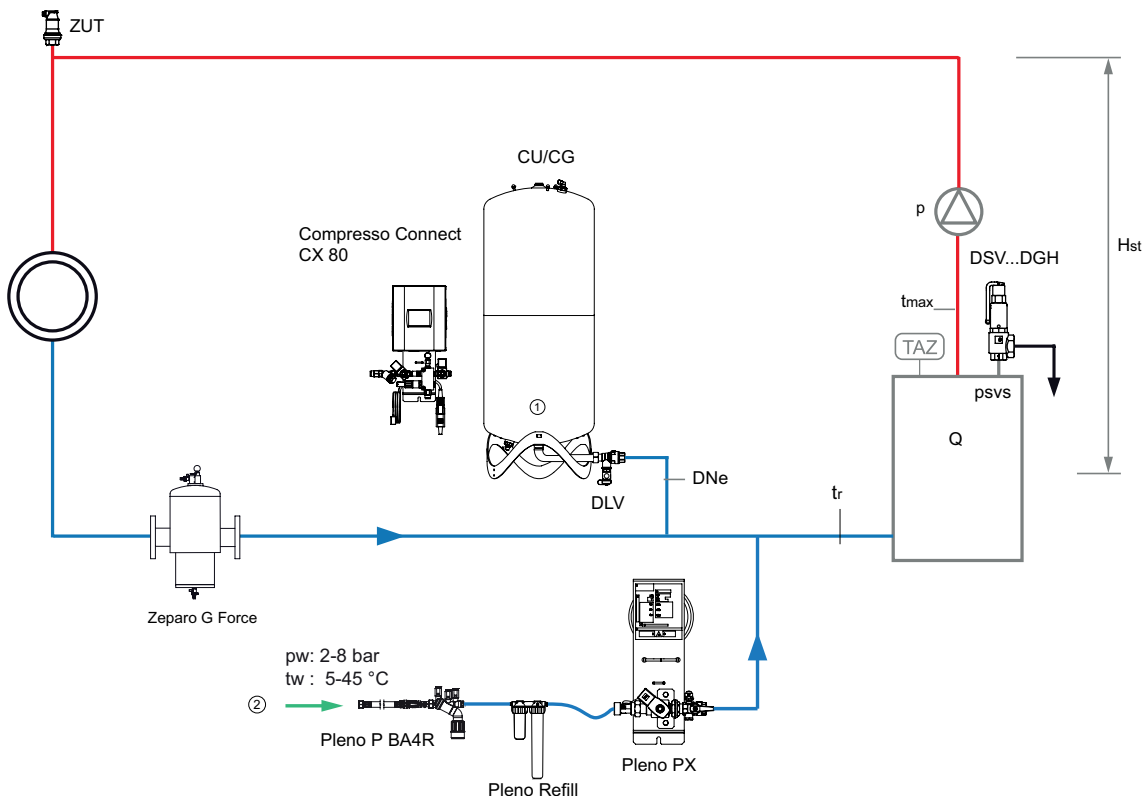

1. Compresso Primary vessel CU

2. Water make-up connection, $p_w \geq p_0 + 1,7$ bar (max. 10 bar)

Zeparo G-Force cyclonic dirt separator with magnet ZGM in the return.

Zeparo ZUT for automatic venting while filling and/or draining.

Further accessories, product and selection details, see: Datasheet *Pleno*, *Zeparo* and *Accessories*.

Installation

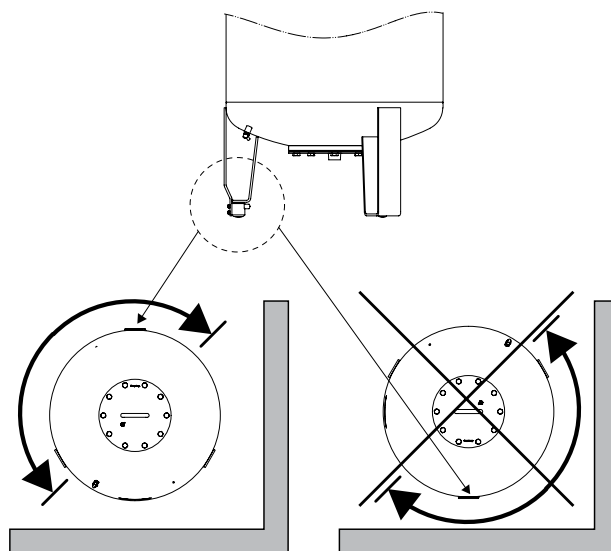
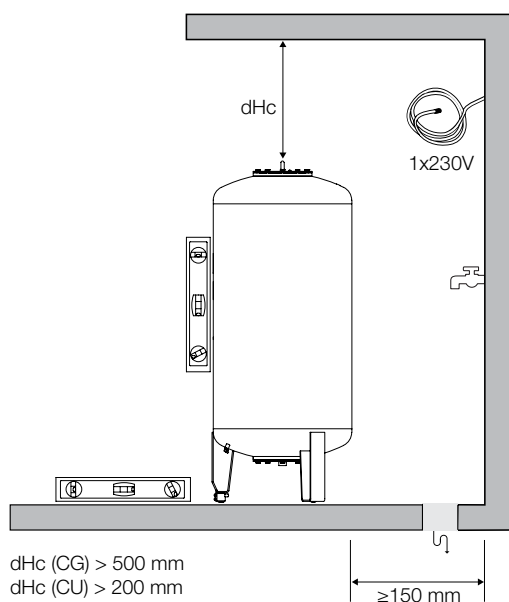
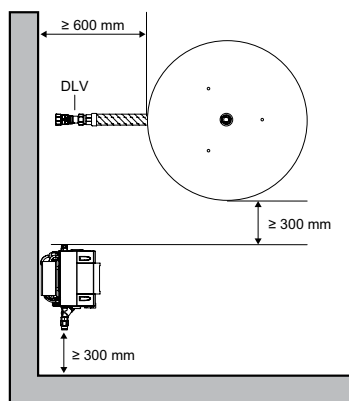
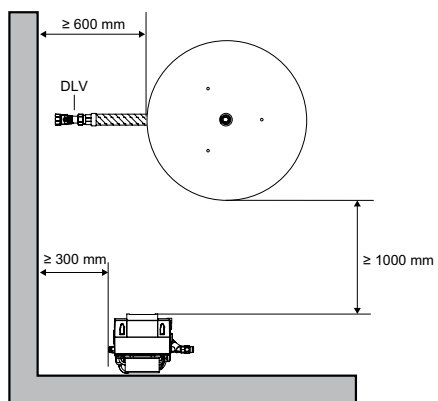

Control unit TecBox, Compresso CX Connect

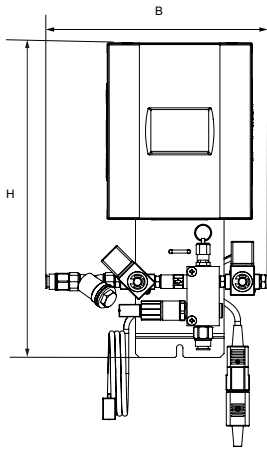

Compresso CX Connect

Precision pressure maintenance ± 0.1 bar

For oil-free external compressed air. 1 air inlet and 1 air exit valve

Type	PS [bar]	B	H	T	m [kg]	Pel [kW]	EAN	Article No
CX 80-6	6	275	392	190	6	0,1	5901688829899	30102130000
CX 80-10	10	275	392	190	6	0,1	5901688829905	30102130001
CX 80-16	16	275	392	190	6	0,1	5901688829912	30102130002

T = Depth of the device

Expansion vessels

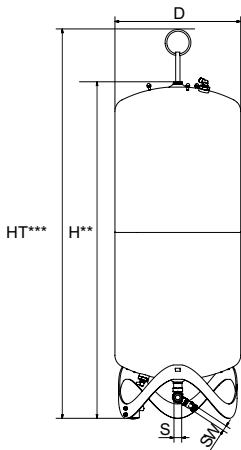

Compresso CU

Primary vessel. Measuring foot for content measurement. Including flex tube for the water-side connection and lock shield valve with ball valve for fast draining.

Type	VN [l]	D	H**	HT***	m [kg]	S	Sw	EAN	Article No
6 bar (PS)									
CU 200.6	200	500	1340	1565	34	Rp1	G3/4	7640148630771	712 1000
CU 300.6	300	560	1469	1690	40	Rp1	G3/4	7640148630788	712 1001
CU 400.6	400	620	1532	1760	58	Rp1	G3/4	7640148630795	712 1002
CU 500.6	500	680	1627	1858	67	Rp1	G3/4	7640148630801	712 1003
CU 600.6	600	740	1638	1873	80	Rp1	G3/4	7640148630818	712 1004
CU 800.6	800	740	2132	2360	98	Rp1	G3/4	7640148630825	712 1005

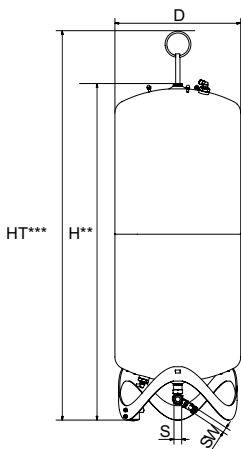

Compresso CU...E

Secondary vessel. Including flex tube for the water-side connection and lock shield valve with ball valve for fast draining, assembly kit for the air-side connection of the vessels.

Type	VN [l]	D	H**	HT***	m [kg]	S	Sw	EAN	Article No
6 bar (PS)									
CU 200.6 E	200	500	1340	1565	33	Rp1	G3/4	7640148630832	712 2000
CU 300.6 E	300	560	1469	1690	39	Rp1	G3/4	7640148630849	712 2001
CU 400.6 E	400	620	1532	1760	57	Rp1	G3/4	7640148630856	712 2002
CU 500.6 E	500	680	1627	1858	66	Rp1	G3/4	7640148630863	712 2003
CU 600.6 E	600	740	1638	1873	79	Rp1	G3/4	7640148630870	712 2004
CU 800.6 E	800	740	2132	2360	97	Rp1	G3/4	7640148630887	712 2005

VN = Nominal volume

***) Tolerance 0 /-100.

***) Maximum height when vessel is tilted, including lifting eyelet

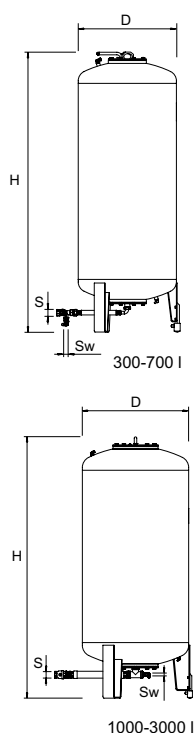

Compresso CG

Primary vessel. Measuring foot for content measurement. Corrosion-protected internal coating for minimum bag wear.

Type*	VN [l]	D	H**	H***	m [kg]	S	Sw	EAN	Article No
6 bar (PS)									
CG 300.6	300	500	1823	1839	140	Rp1	G3/4	7640148630894	712 1006
CG 500.6	500	650	1864	1893	190	Rp1	G3/4	7640148630900	712 1007
CG 700.6	700	750	1894	1931	210	Rp1	G3/4	7640148630917	712 1008
CG 1000.6	1000	850	2097	2132	290	Rp1 1/2	G3/4	7640148630924	712 1009
CG 1500.6	1500	1016	2248	2295	400	Rp1 1/2	G3/4	7640148630931	712 1010
CG 2000.6	2000	1016	2746	2785	680	Rp1 1/2	G3/4	7640148630948	712 1015
CG 3000.6	3000	1300	2850	2936	840	Rp1 1/2	G3/4	7640148630955	712 1012
CG 4000.6	4000	1300	3496	3547	950	Rp1 1/2	G3/4	7640148630962	712 1013
CG 5000.6	5000	1300	4134	4183	1050	Rp1 1/2	G3/4	7640148630979	712 1014
10 bar (PS)									
CG 300.10	300	500	1854	1866	160	Rp1	G3/4	7640148631075	712 3000
CG 500.10	500	650	1897	1921	220	Rp1	G3/4	7640148631082	712 3001
CG 700.10	700	750	1928	1961	250	Rp1	G3/4	7640148631099	712 3002
CG 1000.10	1000	850	2097	2132	340	Rp1 1/2	G3/4	7640148631105	712 3003
CG 1500.10	1500	1016	2285	2331	460	Rp1 1/2	G3/4	7640148631112	712 3004
CG 2000.10	2000	1016	2779	2819	760	Rp1 1/2	G3/4	7640148631129	712 3009
CG 3000.10	3000	1300	2879	2942	920	Rp1 1/2	G3/4	7640148631136	712 3006
CG 4000.10	4000	1300	3524	3576	1060	Rp1 1/2	G3/4	7640148631143	712 3007
CG 5000.10	5000	1300	4169	4211	1180	Rp1 1/2	G3/4	7640148631150	712 3008

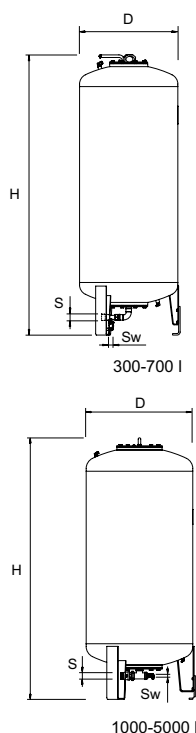

Compresso CG...E

Secondary vessel. Corrosion-protected internal coating for minimum bag wear.

Type*	VN [l]	D	H**	H***	m [kg]	S	Sw	EAN	Article No
6 bar (PS)									
CG 300.6 E	300	500	1823	1839	140	Rp1	G3/4	7640148630986	712 2006
CG 500.6 E	500	650	1864	1893	190	Rp1	G3/4	7640148630993	712 2007
CG 700.6 E	700	750	1894	1931	210	Rp1	G3/4	7640148631006	712 2008
CG 1000.6 E	1000	850	2097	2132	290	Rp1 1/2	G3/4	7640148631013	712 2009
CG 1500.6 E	1500	1016	2248	2295	400	Rp1 1/2	G3/4	7640148631020	712 2010
CG 2000.6 E	2000	1016	2746	2785	680	Rp1 1/2	G3/4	7640148631037	712 2015
CG 3000.6 E	3000	1300	2850	2936	840	Rp1 1/2	G3/4	7640148631044	712 2012
CG 4000.6 E	4000	1300	3496	3547	950	Rp1 1/2	G3/4	7640148631051	712 2013
CG 5000.6 E	5000	1300	4134	4183	1050	Rp1 1/2	G3/4	7640148631068	712 2014
10 bar (PS)									
CG 300.10 E	300	500	1854	1866	160	Rp1	G3/4	7640148631167	712 4000
CG 500.10 E	500	650	1897	1921	220	Rp1	G3/4	7640148631174	712 4001
CG 700.10 E	700	750	1928	1961	250	Rp1	G3/4	7640148631181	712 4002
CG 1000.10 E	1000	850	2097	2132	340	Rp1 1/2	G3/4	7640148631198	712 4003
CG 1500.10 E	1500	1016	2285	2331	460	Rp1 1/2	G3/4	7640148631204	712 4004
CG 2000.10 E	2000	1016	2779	2819	760	Rp1 1/2	G3/4	7640148631211	712 4009
CG 3000.10 E	3000	1300	2879	2942	920	Rp1 1/2	G3/4	7640148631228	712 4006
CG 4000.10 E	4000	1300	3524	3576	1060	Rp1 1/2	G3/4	7640148631235	712 4007
CG 5000.10 E	5000	1300	4169	4211	1180	Rp1 1/2	G3/4	7640148631242	712 4008

VN = Nominal volume

*) Applications > 10 bar and special vessels upon request.

**) Tolerance 0 /-100.

***) Max. height when vessel is tilted

Accessories for control modules

Communication module for BrainCube control

Max. admissible ambient temperature, TA: 40°C

Enclosure class: IP 54

Supply voltage: 230 V/50 Hz

ComCube DCA

2 separated analogue outputs 4-20 mA for connection to BMS, isolation voltage 2.5 kVAC. All cabling inside the casing, wall mounted.

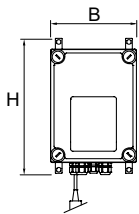

Type	B	H	T	m [kg]	Pel [kW]	EAN	Article No
DCA	190	260	180	0,5	0,1	7640148638739	814 1010

T = Depth of the device

Software expansion

Usage options as Master / Slave, parallel, expanded capacity or 100% redundancy.

Remote switching of Master / Slave possible.

Cabling on site, commissioning by PNEUMATEX Service.

Including assembly kit with shut-offs for the air-side connection of the TecBoxes with the primary vessel.

Master-Slave DMS 2

parallel operation of two Compresso C

Type	EAN	Article No
DMS 2 C	7640148638753	814 1020

Wiring diagrams

230 V / 50/60 Hz

Power supply Compresso CX Connect

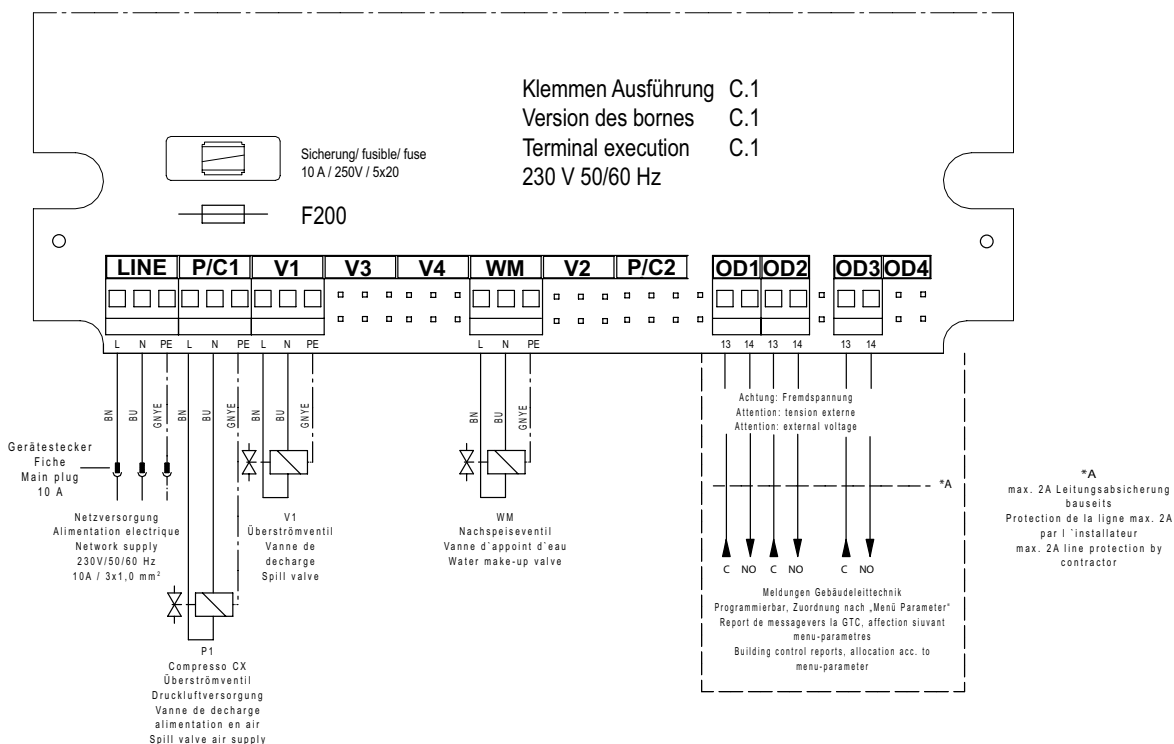

Safety Extra Low Voltage connections

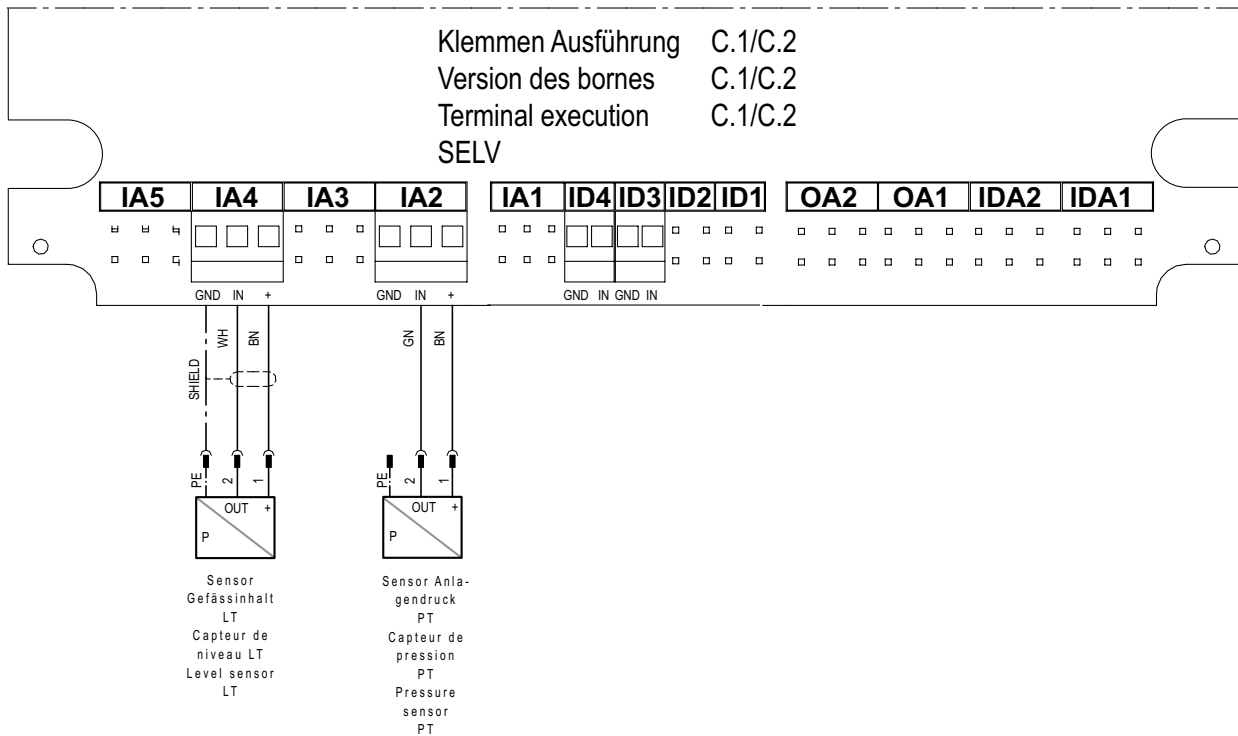

Communication

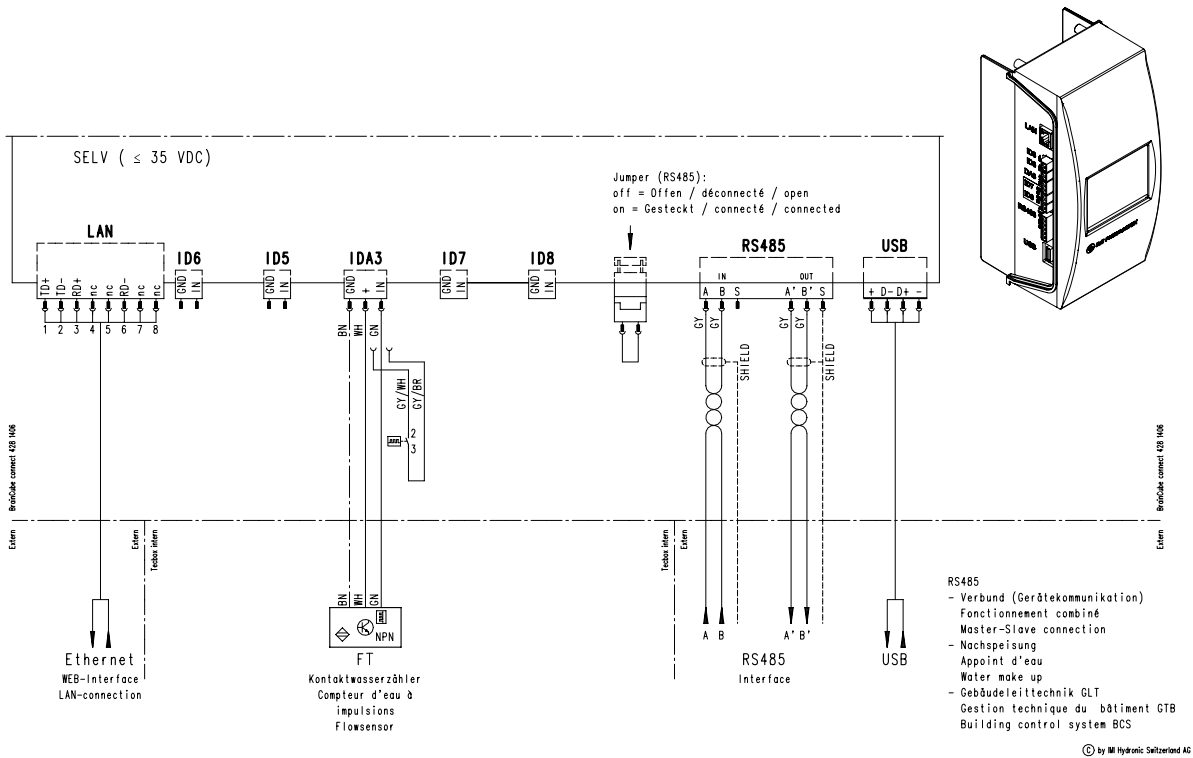

The products, texts, photographs, graphics and diagrams in this document may be subject to alteration by IMI Hydronic Engineering without prior notice or reasons being given. For the most up to date information about our products and specifications, please visit www.imi-hydronic.com.