

DAB 50



Differential pressure relief valves

Proportional relief valve – DN 32-200

DAB 50

This proportional relief valve for heating and cooling systems maintains a minimum flow through the main pipe, minimising the response times of the system's control loops. Its ability to open at times of increasing differential pressure ensures the pumps are protected. Rust protection is assured thanks to the electrophoretically painted ductile iron body.



Key features

- > **Special internal geometry**
Allows big pressure drop without noise.
- > **Adjustable set-point**
Ensure the desired differential pressure.

Technical description

Application:

Heating and cooling systems.

Function:

Maintaining minimum flow through the main pipe to minimize response times of control loops in the system.
Opens at increasing Δp .

Dimensions:

DN 32-200

Pressure class:

PN 16 and PN 25

Max. differential pressure (Δp_V):

1600 kPa = 16 bar

Setting range:

Differential pressure adjustable
10 - 60 kPa, 50 - 150 kPa and
130 - 250 kPa.

Temperature:

Max. working temperature: 150°C
Min. working temperature: -10°C

Media:

Water or neutral fluids, water-glycol mixtures (0-57%).

Material:

Valve body: Ductile iron EN-GJS-400-15
Actuator body: Ductile iron EN-GJS-400-15
Diaphragm: EPDM
Valve seat: Stainless steel
Valve plug: Stainless steel with EPDM insert

Surface treatment:

Electrophoretic painting.

Marking:

IMI TA, DN, PN and flow direction arrow.

Flanges:

According to EN-1092-2:1997, type 21.

Setting

Differential pressure adjustment

1. Release the fixing screw (6).
2. Adjust differential pressure by turning adjustment screw (7).
3. To increase the differential pressure, turn the adjustment screw clockwise (bottom view of the screw).
4. At the end, tighten the fixing screw.
5. The pressures can be controlled through pressure gauges on the pipeline.

Sizing

Select the size according to maximal speed. To prevent noise, maximal speed should not exceed 2 m/s in residential buildings and 3 m/s in industrial buildings.

Control the pressure drop in the valve by formula:

$$\Delta p = \left(\frac{q}{100 \times Kvs} \right)^2 \quad [\text{kPa, l/h}]$$

Operating function

Installation in bypass pipe. The controller consists of a valve (1) and a diaphragm actuator (5). Valve is protected against overload with a safety spring (2).

The pressure upstream the controller acts through an internal impulse pipe ($\Delta p+$), to the top side of the diaphragm (4) and attempts to open the valve.

The pressure downstream the consumer acts through an external impulse pipe ($\Delta p-$) to the bottom side of the diaphragm and attempts to close the valve together with the force of the working spring (8).

As long as the forces on the diaphragm are balanced, the valve's plug stands still. If the differential pressure rises, the valve opens until new balance is reached, and vice versa.

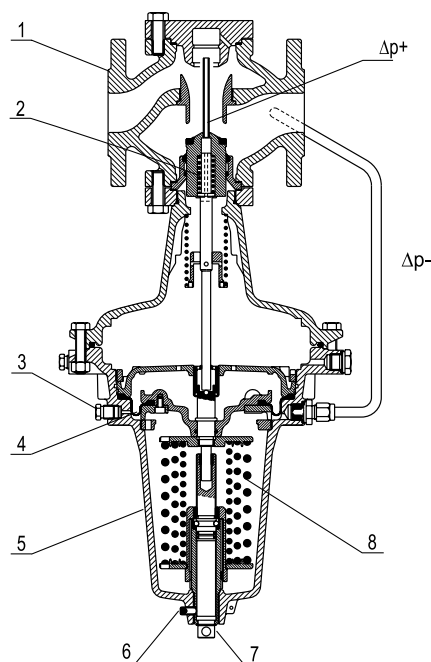

Installation

Install the controller in bypass pipe. The direction of flow is shown by the arrow on the valve body.

It is recommended to install the controller in horizontal pipeline with actuator body below. Installation of a strainer upstream of the controller is recommended.

It is important to ensure that working temperature and pressure do not exceed allowed values.

Before you mount the controller, check the fitting length of the controller, pitch diameter and the diameter of the holes for the screws.

When the pipeline and the controller are full of water and the pressure is stabilized, vent the controller by vent screws (3). Installation of balancing valve STAF is recommended to enable flow measurement, commissioning and troubleshooting with our balancing instrument.

Normal pipe fittings

Try to avoid mounting taps and pumps immediately before the valve.

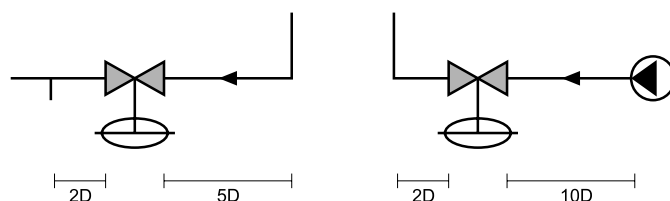

Application example

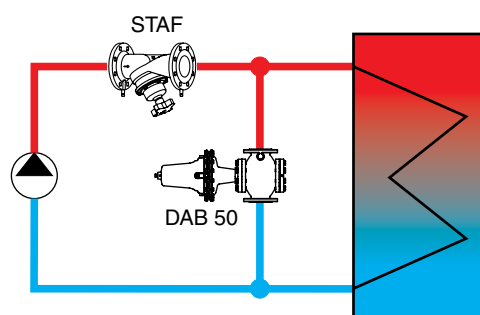

Articles

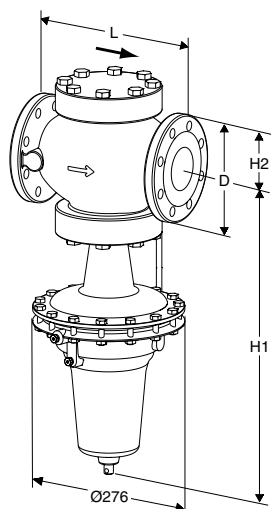
**PN 25** (DN 32-50 and DN 80 also fit PN 16 flanges)

DN	D	L	H1	H2	Kvs	Kg	EAN	Article No
10-60 kPa								
32	140	180	535	102	21	38	3831112518346	52 789-332
40	150	200	535	102	25	39	3831112518407	52 789-340
50	165	230	560	116	32	46	3831112518469	52 789-350
65	185	290	580	135	55	55	3831112518582	52 789-365
80	200	310	592	149	70	66	3831112518643	52 789-380
100	235	350	680	175	120	88	3831112517929	52 789-390
125	270	400	690	190	145	105	3831112518049	52 789-391
150	300	480	775	227	230	235	3831112518162	52 789-392
200	360	600	822	260	360	297	3831112518285	52 789-393
50-150 kPa								
32	140	180	535	102	21	38	3831112518384	52 789-432
40	150	200	535	102	25	39	3831112518445	52 789-440
50	165	230	560	116	32	46	3831112518506	52 789-450
65	185	290	580	135	55	55	3831112518629	52 789-465
80	200	310	592	149	70	66	3831112518681	52 789-480
100	235	350	680	175	120	88	3831112517967	52 789-490
125	270	400	690	190	145	105	3831112518087	52 789-491
150	300	480	775	227	230	235	3831112518209	52 789-492
200	360	600	822	260	360	297	3831112518322	52 789-493
130-250 kPa								
32	140	180	535	102	21	38	3831112518360	52 789-532
40	150	200	535	102	25	39	3831112518421	52 789-540
50	165	230	560	116	32	46	3831112518483	52 789-550
65	185	290	580	135	55	55	3831112518605	52 789-565
80	200	310	592	149	70	66	3831112518667	52 789-580
100	235	350	680	175	120	88	3831112517943	52 789-590
125	270	400	690	190	145	105	3831112518063	52 789-591
150	300	480	775	227	230	235	3831112518186	52 789-592
200	360	600	822	260	360	297	3831112518308	52 789-593

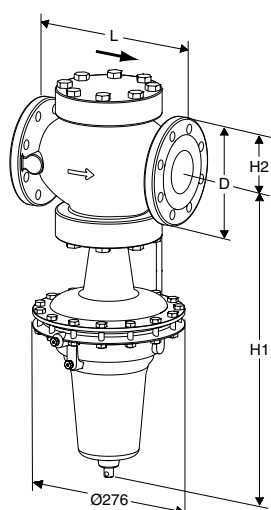
**PN 16**

DN	D	L	H1	H2	Kvs	Kg	EAN	Article No
10-60 kPa								
65	185	290	580	135	55	55	3831112518520	52 789-065
100	235	350	680	175	120	88	3831112517868	52 789-090
125	270	400	690	190	145	105	3831112517981	52 789-091
150	300	480	775	227	230	235	3831112518100	52 789-092
200	360	600	822	260	360	297	3831112518223	52 789-093
50-150 kPa								
65	185	290	580	135	55	55	3831112518568	52 789-165
100	235	350	680	175	120	88	3831112517905	52 789-190
125	270	400	690	190	145	105	3831112518025	52 789-191
150	300	480	775	227	230	235	3831112518148	52 789-192
200	360	600	822	260	360	297	3831112518261	52 789-193
130-250 kPa								
65	185	290	580	135	55	55	3831112518544	52 789-265
100	235	350	680	175	120	88	3831112517882	52 789-290
125	270	400	690	190	145	105	3831112518001	52 789-291
150	300	480	775	227	230	235	3831112518124	52 789-292
200	360	600	822	260	360	297	3831112518247	52 789-293

Kvs = m³/h at a pressure drop of 1 bar and fully open valve.

→ = Flow direction

