

TBV-C – NPT threads



Combined control & balancing valves for small terminal units

For ON-OFF control

TBV-C – NPT threads

Designed for use in terminal units in heating and cooling systems, the TBV-C ensures accurate hydronic control and optimum throughput over a long lifetime. IMI Hydronic Engineering's dezincification resistant alloy, AMETAL®, minimises the risk of leakage.

Key features

- > **Presetting tool**
For accurate and easy balancing.
- > **Self-sealing measuring points**
For quick and easy measurement.
- > **Shut-off function**
Ensures straightforward maintenance procedures.



Technical description

Application:

Heating (not steam) and cooling systems.

Functions:

Control
Balancing
Pre-setting
Measuring
Shut-off (for isolation during system maintenance)

Dimensions:

DN 15-25

Pressure class:

PN 16

Temperature:

Max. working temperature: 120°C
Min. working temperature: -20°C

Leakage rate:

Tight sealing

Material:

Valve body: AMETAL®
Seat seal: Valve disc of EPDM
Spindle seal: EPDM O-ring
Valve insert: AMETAL®, PPS (polyphenylsulphide)
Return spring: Stainless steel
Spindle: AMETAL®

AMETAL® is the dezincification resistant alloy of IMI Hydronic Engineering.

Marking:

Body: TA, PN 16/150, DN, inch size and flow direction arrow.

Identification ring on measuring point:
White = Low flow (LF)
Black = Normal flow (NF)

Actuators:

See separate information on EMO T.

Sizing

When Δp and the design flow are known, use the formula to calculate the Kv-value.

$$Kv = 0,01 \frac{q}{\sqrt{\Delta p}} \quad q \text{ l/h, } \Delta p \text{ kPa}$$

$$Kv = 36 \frac{q}{\sqrt{\Delta p}} \quad q \text{ l/s, } \Delta p \text{ kPa}$$

Setting

TBV-C is delivered with a red protective cap, Article No 52 143-100, which must be used when isolating the valve.

TBV-C is delivered with the pre-setting fully open. The setting of a valve for a given pressure drop, e.g. corresponding to position 5 is done as follows:

1. Place the presetting tool, Article No 52 133-100, at the valve.
2. Turn the presetting tool so that position 5 is pointing at the index* of the valve body.
3. Remove the presetting tool. The valve is now set.

There is a diagram for every valve size that shows the flow for different pressure drops and settings.

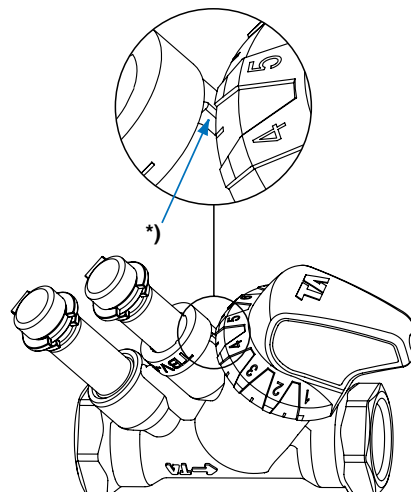

Noise

The following conditions must be fulfilled in order to avoid noise in the heating system:

- Flows correctly balanced
- The water in the system must have been de-aerated
- Circulation pumps which do not generate excessive differential pressures (alternatively use a differential pressure controller, e.g. STAP)

The maximum recommended pressure drop in order to avoid noise is 30 kPa = 0,3 bar.

Measuring accuracy

Flow deviation at different settings



*) Position

Try to avoid mounting taps and pumps, immediately before the valve.

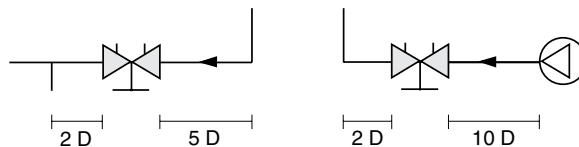

Installation

Application example

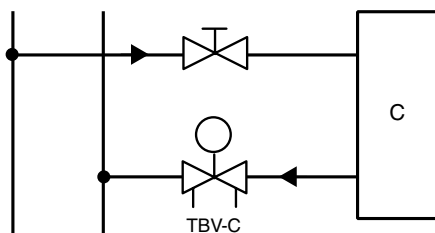

Flow direction

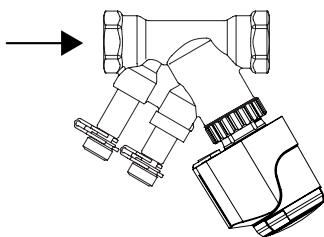

Installation of actuator EMO T

Approx. 15 mm of free space is required above the actuator.

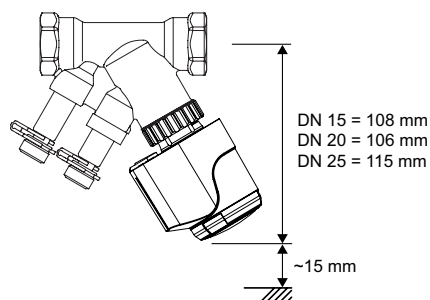

TBV-C + EMO T

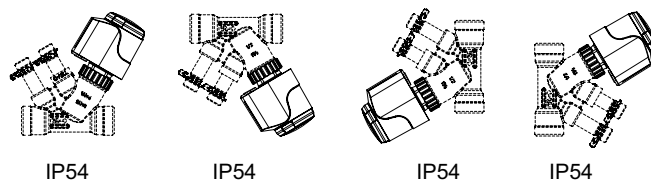

Closing force

Necessary force (F) to close the valve versus the differential pressure (Δp).

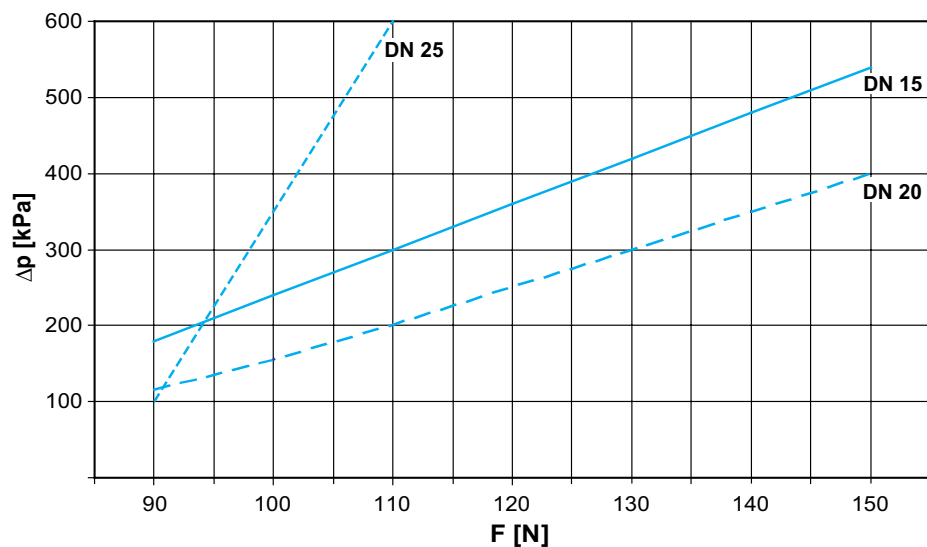
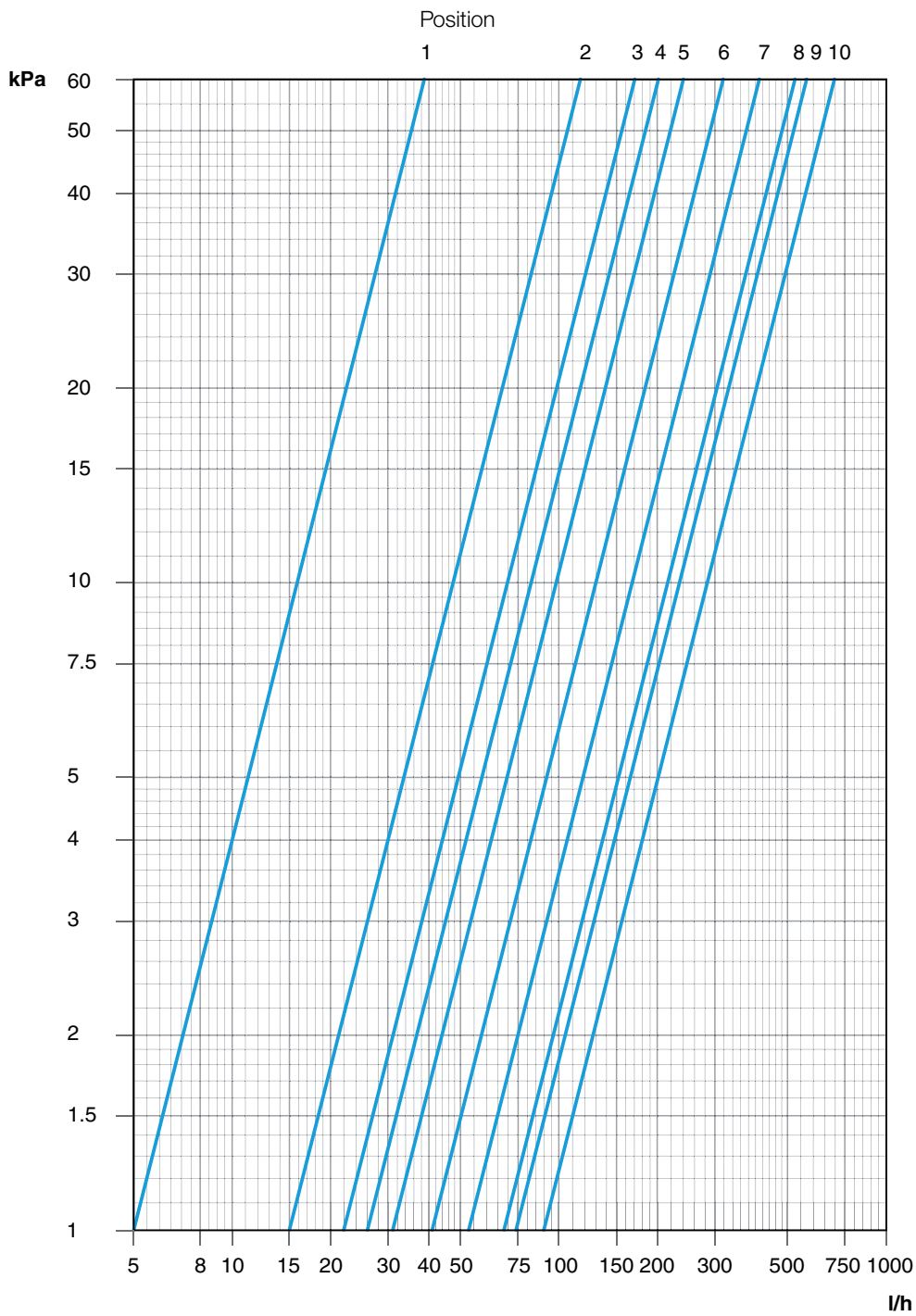

Diagram TBV-C LF, DN 15



Position	1	2	3	4	5	6	7	8	9	10
Kv	0,05	0,15	0,22	0,26	0,31	0,41	0,53	0,68	0,74	0,90

Recommended setting: Position 3-10

Diagram TBV-C NF, DN 15

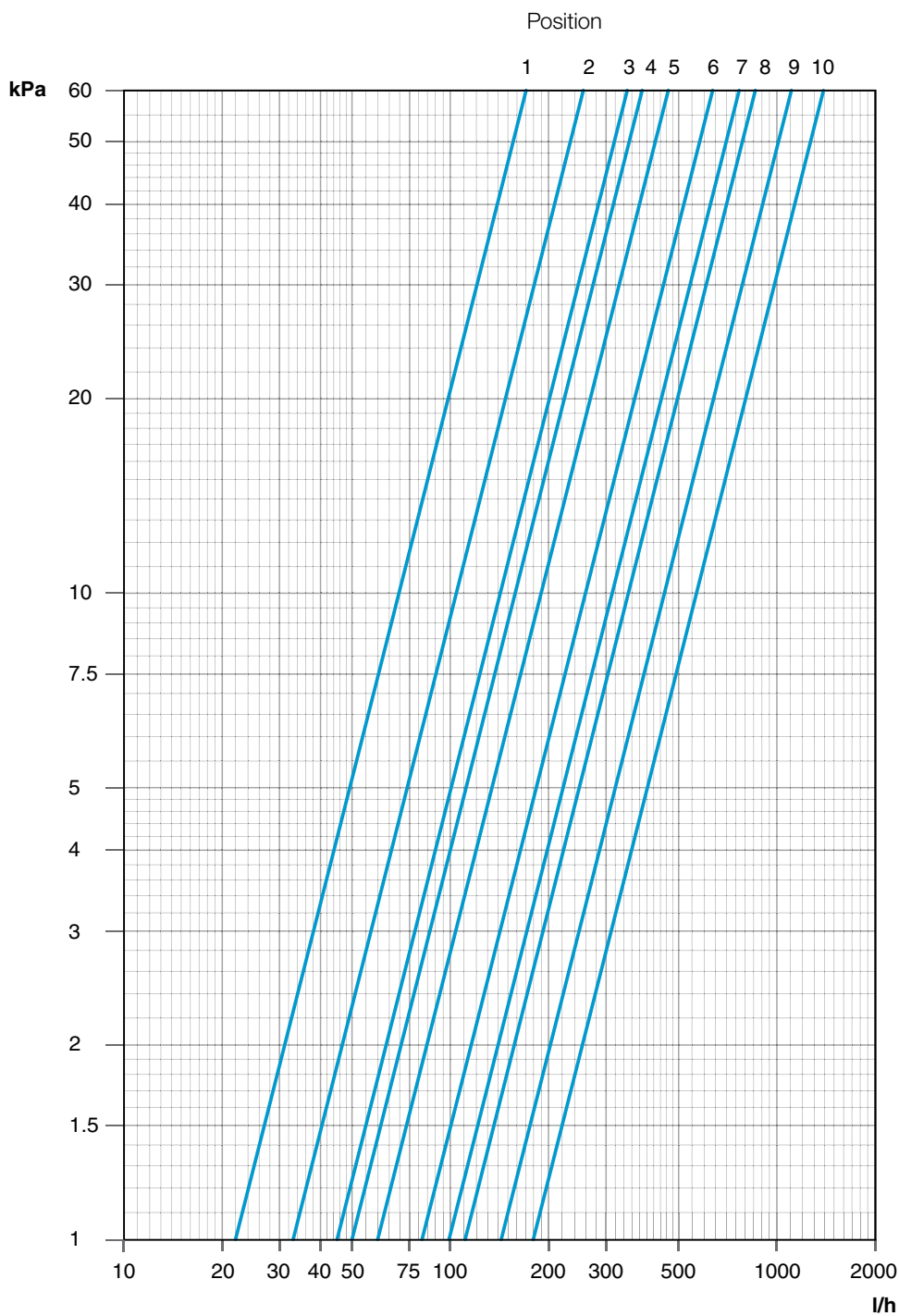

Position	1	2	3	4	5	6	7	8	9	10
Kv	0,22	0,33	0,45	0,50	0,60	0,82	0,99	1,1	1,4	1,8

Recommended setting: Position 3-10

Diagram TBV-C NF, DN 20

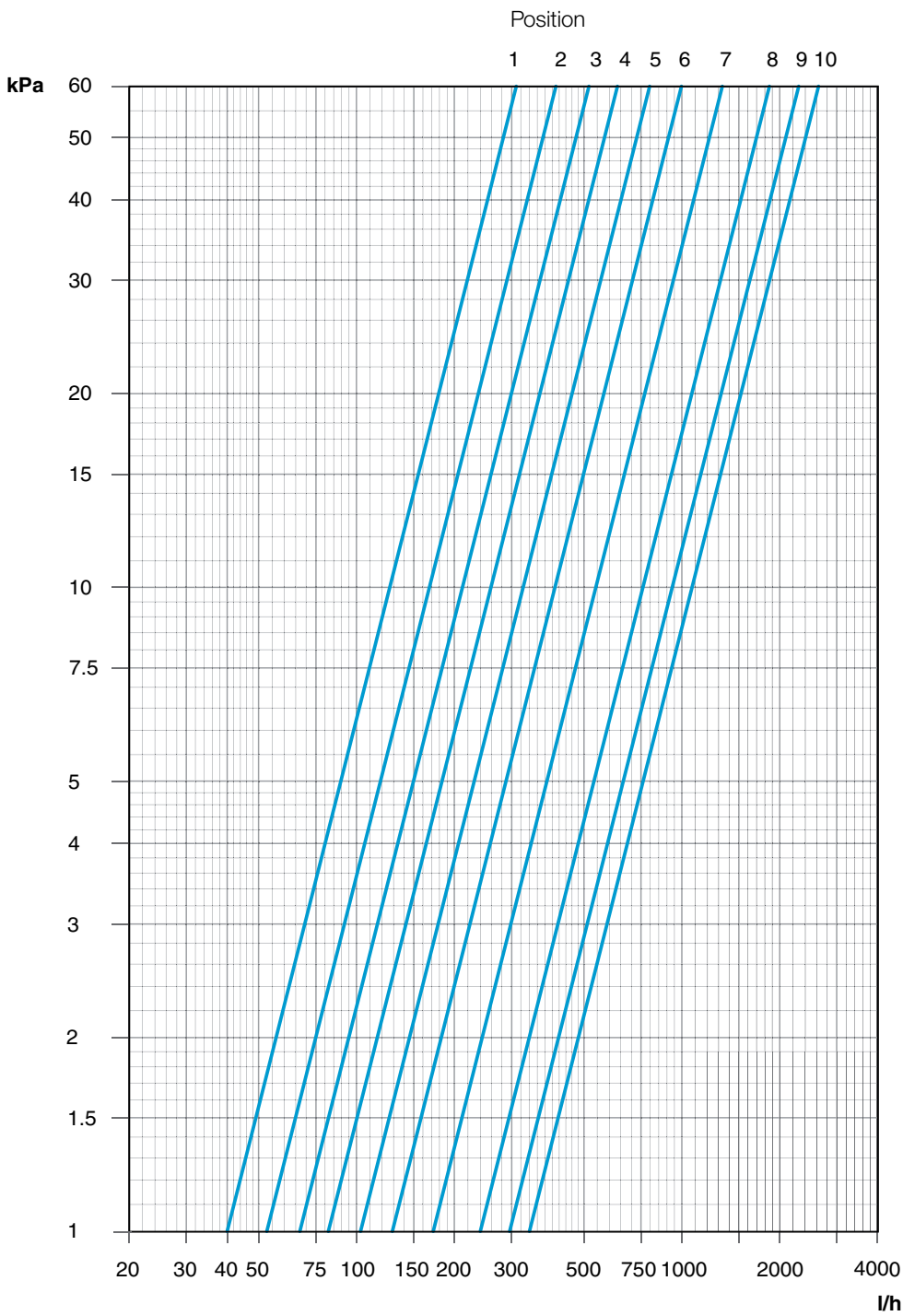

Position	1	2	3	4	5	6	7	8	9	10
Kv	0,40	0,53	0,67	0,82	1,0	1,3	1,7	2,4	3,0	3,4

Recommended setting: Position 3-10

Diagram TBV-C NF, DN 25

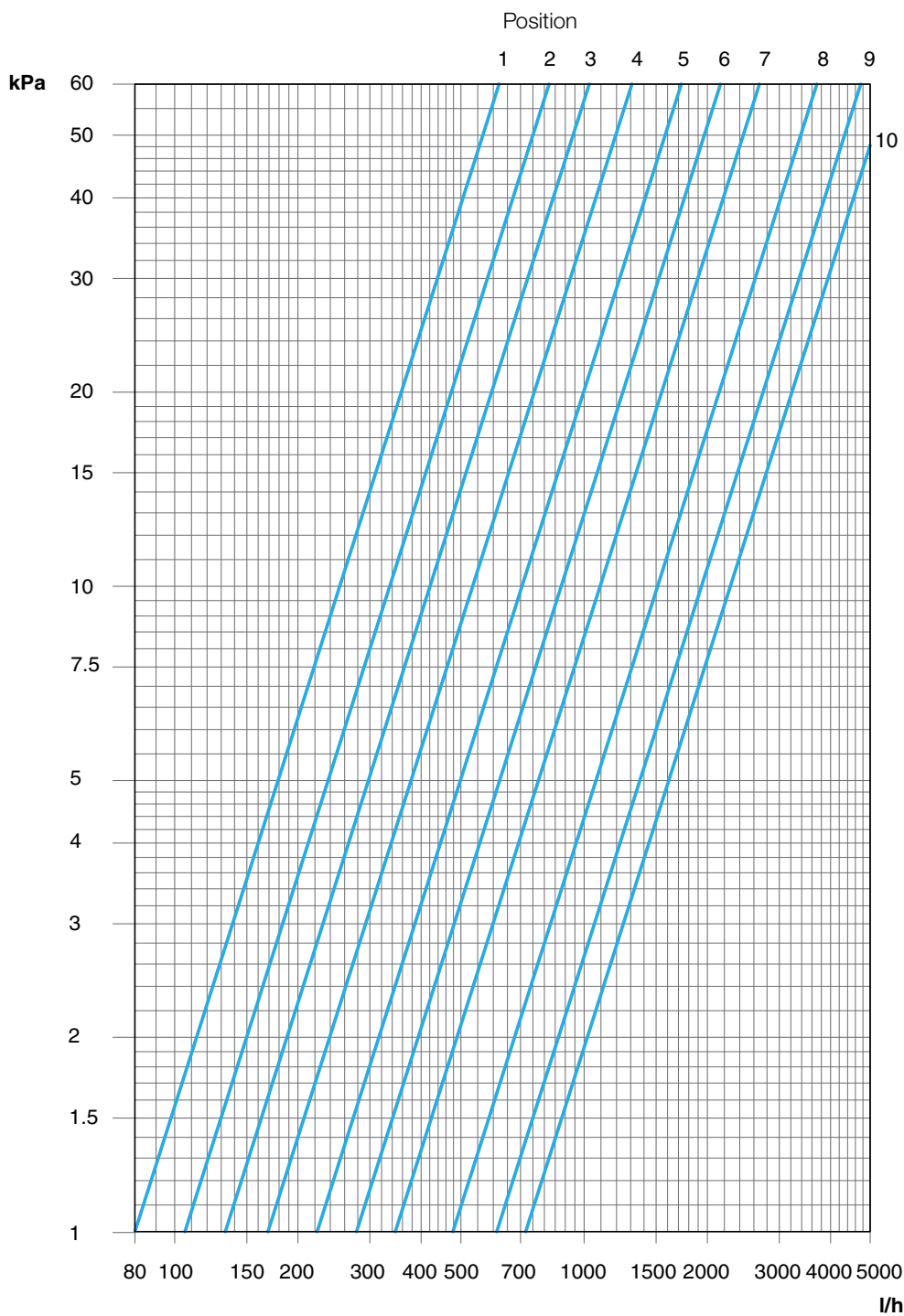

Position	1	2	3	4	5	6	7	8	9	10
Kv	0,80	1,0	1,3	1,7	2,2	2,8	3,5	4,8	6,1	7,2

Recommended setting: Position 3-10

Articles

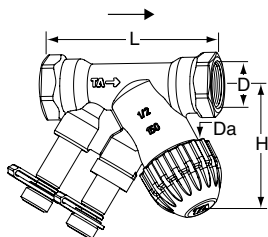

Female thread

DN	Size	D	Da*	L	H	Kvs	Kg	EAN	Article No
TBV-C LF, low flow									
15	1/2"	1/2 NPT	M30x1,5	81	58	0,90	0,50	7318794019706	52 133-515
TBV-C NF, normal flow									
15	1/2"	1/2 NPT	M30x1,5	81	58	1,8	0,50	7318793949707	52 134-515
20	3/4"	3/4 NPT	M30x1,5	91	57	3,4	0,40	7318793949806	52 134-520
25	1"	1 NPT	M30x1,5	111	64	7,2	0,73	7318794021709	52 134-525

*) Connection to actuator.

Kvs = m³/h at a pressure drop of 1 bar and fully open valve.

→ = Flow direction

Accessories

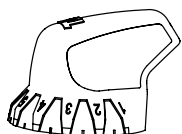

Presetting tool

For TBV-C, TBV-CM

EAN

Article No

7318793886002

52 133-100

Actuator EMO T

For more details of EMO T, see separate catalogue leaflet.

TBV-C is developed to work together with the EMO T actuator. Actuators of other brands require a working range of:

X (closed - fully open) = 11,4 - 15,1 (DN 15-20) / 11,4 - 15,8 (DN 25)

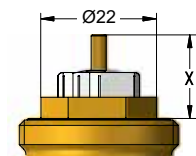

IMI Hydronic Engineering will not be held responsible for the control function if actuators other brand than IMI TA are used.

