

KTM 50 – ANSI flanges



Combined control & balancing valves

Pressure independent balancing and control valve



Engineering
GREAT Solutions

KTM 50 – ANSI flanges

High-performing pressure-independent temperature control valve for variable flow heating and cooling systems. Particularly effective in situations requiring high temperatures and/or pressure drops, e.g. for the primary side of district heating and industrial cooling. Also suitable for use on the secondary side in district heating and comfort cooling systems. Rust protection is assured due to the electrophoretically painted ductile iron body.



Key features

- > **Special internal geometry**
Allows big pressure drop without noise.
- > **Adapters**
For use with most available actuators.
- > **Adjustable flow**
Ensures the design flow.

Technical description

Application:

Heating and cooling systems with variable flow.

Function:

Temperature control, differential pressure control over an integrated control valve and flow control.

Dimensions:

DN 100-200

Pressure class:

Class 150

Max. differential pressure (Δp_V):

1600 kPa = 16 bar

Pressure drop in the throttle (F_c):

DN 100-200: 15 kPa
DN 200 HF: 34 kPa
HF = high flow

Temperature:

Max. working temperature: 150°C
Min. working temperature: -10°C

Media:

Water or neutral fluids, water-glycol mixtures.

Leakage rate:

Tight sealing

Material:

Valve body: Ductile iron EN-GJS-400
Diaphragms and gaskets: EPDM
Valve plug: Stainless steel with EPDM insert

Surface treatment:

Electrophoretic painting.

Marking:

IMI TA, DN, PN, Kvs, CE, valve body material and flow direction arrow.

Flanges:

According to ASME/ANSI B16.42
Class 150.

Max. lift of the control valve:

20 mm

Operating function

Bonnet for temperature control (1) and diaphragm operated differential pressure controller (2) are built in one valve body. Pressure upstream of the control valve acts through an external impulse pipe (V+) to bottom side of the diaphragm (3). Pressure downstream control valve (V-) acts to top side of diaphragm together with a spring (4) force. The differential pressure controller pressure relieves the control valve and at the same time limits the flow to the value preset via lift limitation of control valve. The differential pressure controller keeps 15 kPa (34 kPa) across the control valve. Valve is protected against overload with a safety spring (5). Valve is protected against overload with a safety spring (5).

- 1. Bonnet
- 2. Δp controller
- 3. Diaphragm
- 4. Spring
- 5. Safety spring
- 6. Vent screw

V+ External impulse pipe
V- Internal impulse pipe

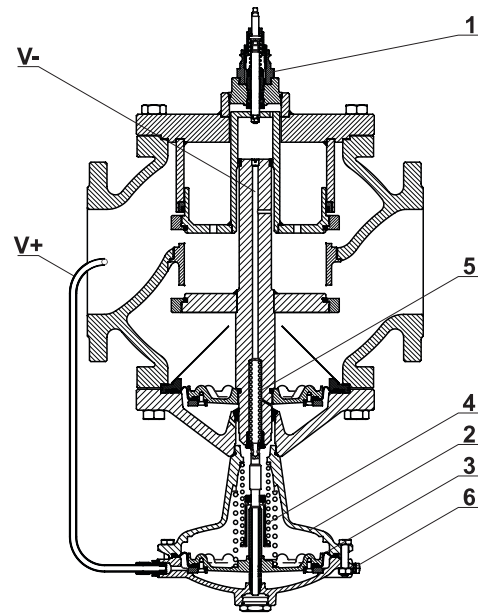

Sizing

Select the size according to maximum flow. Control the pressure drop in the valve by using the formula:

Fc is the constant pressure drop in the throttle (15 kPa, 34 kPa).

$$\Delta P_{\min} = F_c + \left(0.01 \frac{q}{K_{vd}} \right)^2 \quad [l/h, \text{kPa}]$$

Installation

Flow direction is shown by the arrow on the valve body. Install the valve so that the flow adjustment scale is visible and measuring points (if used) are accessible. Check the allowed positions of the actuator. Installation of a strainer upstream of the valve is recommended. Install the actuator after undertaken a leakage test. Installation of a balancing valve STAF is recommended to enable flow measurement, commissioning and trouble-shooting with IMI Hydronic Engineering's balancing or measuring instruments.

Normal pipe fittings

Try to avoid mounting taps and pumps immediately before the valve.

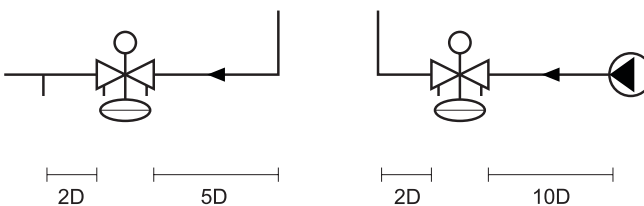

Application example

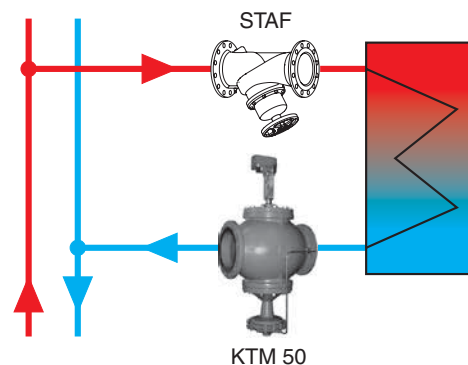

Setting

Release the fixing nut (7). Turn the flow setting screw (8) clockwise to the position of 0,0 turns. Turn the flow setting screw **anticlockwise** corresponding to the number of turns on the flow chart. Tighten the fixing nut.

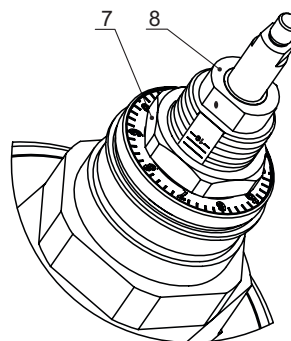

Articles

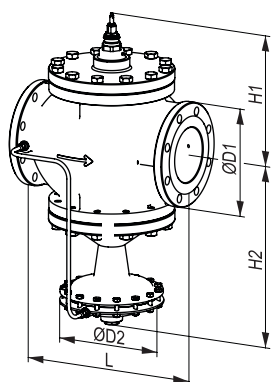

Flanged

Flanges according to ASME/ANSI B16.42 Class 150.

Class 150

DN	D1	D2	L	H1	H2	Kvd	q _{max} [m ³ /h]	Kg	EAN	Article No
Fc = 15 kPa										
100	229	276	350	346	461	120	80	78	3831112529984	52 764-890
125	254	276	400	356	471	145	90	95	3831112529991	52 764-891
150	279	276	480	392	498	230	190	225	3831112530003	52 764-892
200	343	276	600	430	540	360	215	287	3831112530010	52 764-893
Fc = 34 kPa										
200 HF	343	276	600	430	540	430	350	287	3831112534094	52 767-293

Fc is constant pressure drop in the control valve = 15 kPa (34 kPa).

Kvd = Is the Kv value of the differential pressure control component when fully open, used to calculate the minimum pressure drop necessary for the valve to operate according to the formula found under "Sizing".

HF = high flow

Adapters for actuators

For actuator	EAN	Article No
Belimo UNV 003, TA-NV24	3831112512283	52 757-901
Sauter AVN 224, AVF 234, AVM 234	3831112504486	52 757-904
TA-Slider 1250, TA-MC100	3831112512085	52 757-907
TA-MC100 FSE/FSR	3831112511781	52 757-912
TA-MC160/230	3831112511910	52 757-913

